



# *The Bose® Acoustimass® -10 Home Theater Speaker System*

*Owner's Guide*

*December 20, 2001*

AM183644\_01.pdf

## Thank you

We appreciate your choice of the Bose® Acoustimass®-10 home theater speaker system. With these Virtually Invisible® speakers you'll surround yourself with realistic sound, without a lot of equipment.

## For your records

The serial number is located near the connection panel on the Acoustimass module.

Serial number: \_\_\_\_\_

Dealer name: \_\_\_\_\_

Dealer phone: \_\_\_\_\_ Purchase date: \_\_\_\_\_

We suggest you keep your sales slip and warranty card together with this owner's guide.

## Declaration of Conformity

We, the offerer:

Bose® Corporation, The Mountain  
Framingham, MA 01701-9168 USA

acknowledge our sole responsibility, that the product:

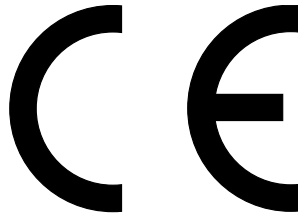

Kind of equipment:	<b>Loudspeakers</b>
Type designation:	<b>Acoustimass® -10 Home Theater Speakers</b>

in accordance with EMC Directive 89/336/EEC and Article 10(1) of the Directive,  
is in compliance with the following norm(s) or document(s):

Technical regulations:	<b>EN50081-1, EN50082-1</b>
------------------------	-----------------------------

Accredited by Bose Corporation

**3 January 1996**

Bose B.V., Nijverheidstraat 8  
1135 GE Edam, The Netherlands

A handwritten signature in black ink that reads "Paul Olean".

Paul Olean, General Manager, Bose Europe  
Manufacturer's authorized EU  
representative

*Where to find...*

Introduction

- Thank you ..... 2
- For your records ..... 2

Setting Up

- Before you begin ..... 4
- Unpack the carton ..... 4
- Placing your Acoustimass®-10 speakers to achieve realistic home theater sound .... 5
- Select the locations for your speakers ..... 6
  - Left and right front cube speakers ..... 6
  - Center cube speaker ..... 6
  - Surround cube speakers ..... 7
  - Acoustimass module ..... 7
- Connect the speakers ..... 8
  - Use the cable correctly ..... 8
  - Connect the Acoustimass module to the center and front cube speakers ..... 9
  - Connect the Acoustimass module to the surround cube speakers ..... 9
  - Connect the Acoustimass module to the receiver ..... 9
  - Check the connections ..... 10

Using Your Acoustimass-10 speakers

- For realistic home theater sound ..... 11
  - How to set your Pro-Logic receiver ..... 11
  - Bass and treble adjustments ..... 11
  - Set your Dolby AC-3 receiver correctly ..... 11

Maintaining Your Acoustimass-10 speakers

- Troubleshooting ..... 12
- Customer service ..... 12
- Cleaning the speakers ..... 13
- Warranty period ..... 13

Product Information

- Technical information ..... 14
- Accessories ..... 14

Bose® Corporation ..... inside back cover

## Before you begin

Bose® Virtually Invisible® speaker technology allows you to enjoy lifelike home performances from the very latest surround sound encoded movies, CDs, and television shows, without a room full of speakers.

Your stereo VCR or stereo television sends the encoded program material to the surround sound receiver, which interprets it by distributing various sounds to particular speakers. Although the sound mix varies with different types of programs, dialogue is usually sent to the center speaker while sounds from the left or right side of the picture go to the left or right front speakers. Ambient sounds and special effects are directed to one or both of the surround (rear) speakers. The unique, easy-to-hide Acoustimass® module delivers bass for all channels. At any point in a surround sound performance, you may hear sound from all or just a few of the speakers, but the overall experience puts you in the center of the action.

To select surround-encoded program material, look for any of the terms Surround, Dolby Surround, and the double-D symbol  **DOLBY SURROUND** \* on tapes and discs, and the word "surround" preceding a TV broadcast. Your Acoustimass-10 home theater speakers are also compatible with Dolby AC-3 receivers and program material. The special settings for Dolby Surround and AC-3 are described on page 11.

You can also enjoy a wide variety of stereo programming that is not surround-encoded with your Acoustimass-10 speakers. Simply adjust your receiver accordingly.

## Unpack the carton

- Remove any staples from the opened carton flaps.
- Remove the brown inner carton containing the five cube speaker arrays and the Acoustimass module terminal cover.
- Gently roll the carton over onto its side and then onto its opening.
- Carefully lift the carton from around the Acoustimass module and packing cushions.
- Do not detach the removable cables connected to the Acoustimass module.
- If the speakers or the Acoustimass module appear damaged, do not use them. Repack everything in the original carton and contact your authorized Bose dealer immediately.

*Note: Now is a good time to record the serial number of these speakers on page 2 of this guide and on your warranty card. It is a good idea to save all packing materials for possible future use.*

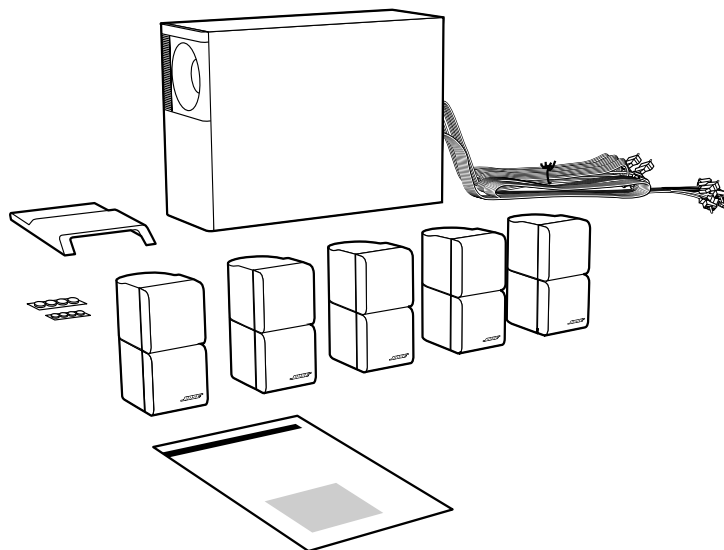

### WARNING:

*The Acoustimass module weighs 23 pounds (10.5 kg). Use good lifting practice to avoid injury.*

*To avoid danger of suffocation, keep the plastic bags that wrap these speakers out of the reach of children.*

## Figure 1

What comes in the carton:

- Acoustimass module
- Module end cover
- 5 cube speaker pairs
- 20' (6 m) speaker input cable
- 20' (6 m) front speaker output cable
- 50' (15 m) rear speaker output cable
- 8 protective rubber feet
- Owner's Guide

\* Dolby and the double-D symbol are trademarks of Dolby Laboratories Licensing Corporation.

## Placing your Acoustimass®-10 speakers to achieve realistic home theater sound

The center speaker localizes action and dialogue on your screen. Sound from the center speaker should seem to come from within the picture.

The left and right front speakers create a sound image wider than the screen that seems natural to viewers sitting anywhere in the room.

The surround speakers add subtle sounds and special effects that expand the visual image, bringing the viewer into the center of the action. The surround speakers should be positioned to allow the sound to reach the viewer from both sides, rather than from directly behind.

You can place the front and center speakers near a TV screen with no picture interference, because all of the cube speakers are magnetically shielded.

The Acoustimass module is not magnetically shielded and should be at least 2 feet (.6 m) from your screen, but at the same end of the room as the front and center speakers. Bose® Acoustimass speaker technology takes advantage of the fact that the source of bass sound is difficult to locate, so you can hide the Acoustimass module conveniently out of sight.

A suggested home theater layout that conforms to the guidelines described above is shown in Figure 2. Twist the pairs of cube speakers so they describe angles that create room-filling sound patterns.

You may choose to place the speakers differently, to take advantage of the sound characteristics of different rooms. Your speakers come with sufficient cable lengths to allow you to have the following distances between components:

- Up to 20 feet (6 m) between the Acoustimass module and the receiver.
- Up to 20 feet (6 m) between the Acoustimass module and the front and center cube speakers.
- Up to 50 feet (15 m) between the Acoustimass module and the surround speakers.

Bose wall brackets and floor stands can extend your placement options. See “Accessories” on page 14.

### NOTE:

*Please follow wall bracket instructions carefully. Proper mounting will insure optimum performance from your system.*

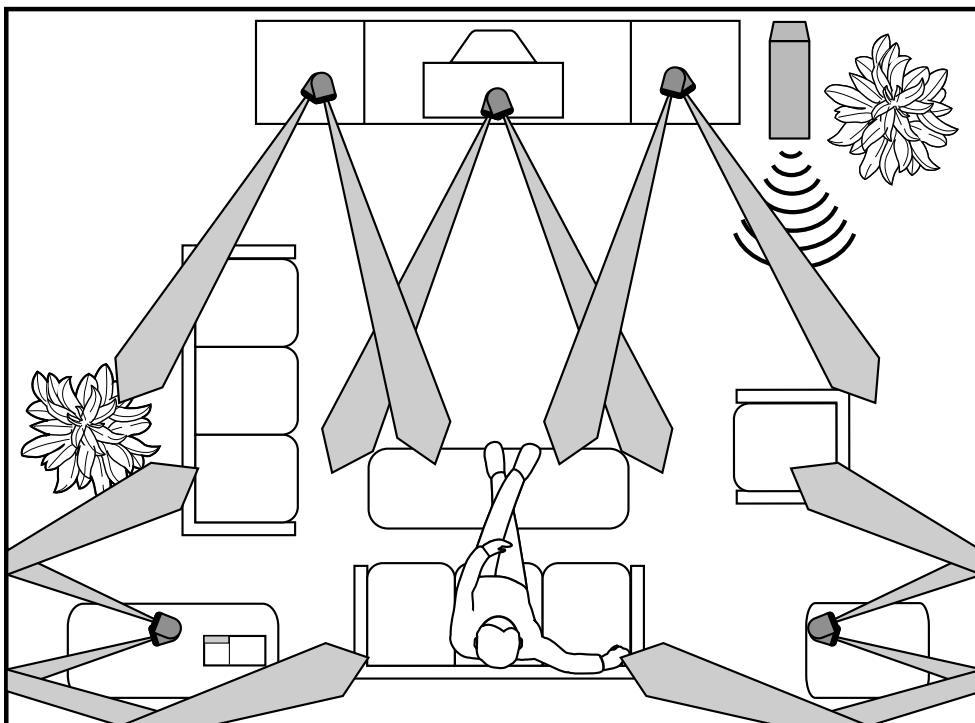

**Figure 2**

One suggested home theater layout

## Select the locations for your speakers

The cables provided with your Acoustimass®-10 system vary in length and provide a great deal of flexibility in speaker placement.

### Left and right front cube speakers

Use the two cube speakers with black terminals. Figure 3 shows suggested ways to achieve an accurate left and right sound image.

- Place the front speakers on either side of your TV, at least 6 feet (2 m), or as much as 15 feet (5 m) apart.
- Place them in line with the center of the screen for the best sound balance (position 1). Or, place them in a lateral position, with one high and the other low (position 2). Placing them in a line above the top of the TV is a third choice (position 3).
- The speaker on the left as you face the TV is connected to the LEFT FRONT jack on the Acoustimass module.

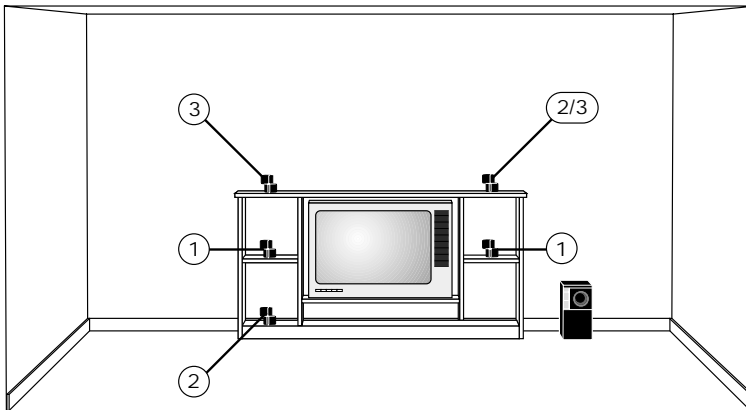

Figure 3

Suggested choices for left and right front speaker placement

**CAUTION:** If you are placing the center speaker on top of the television, use the smaller of the two sets of four rubber feet provided. This will provide extra stability on surfaces such as marble or glass. Additional rubber feet are available, free, by calling the Bose® customer service numbers inside the back cover of this manual. Ask for Part Number 178321-04.

### Center cube speaker

Select one speaker with a gray terminal for the front center speaker. Sound from the center speaker should seem to come from within the picture.

Figure 4 shows suggested positions for the center speaker.

- Place the center cube speaker above, below, or on top of your television. If below, be sure that the cube speaker is not supporting the weight of the television in any way.
- Keep it as close to the vertical center of the screen as possible, for the most accurate dialogue reproduction (positions 1 or 2).

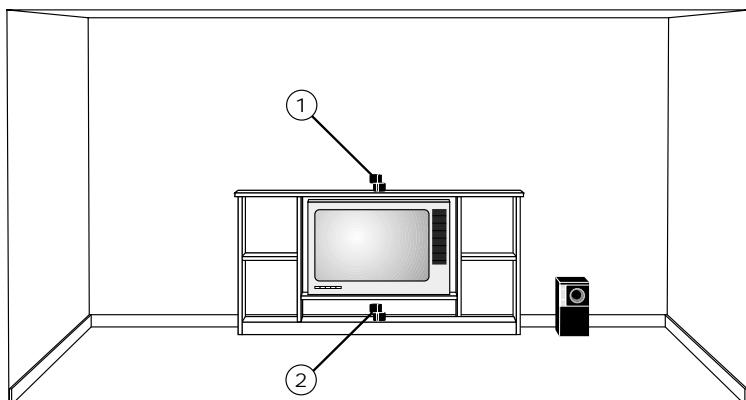

Figure 4

Suggested choices for center speaker placement

### Surround cube speakers

The remaining two speakers with gray terminals are to be used as surround speakers. The left and right rear channel sound should reach the viewer from both sides, rather than from directly behind. Refer to Figure 5.

- Put one on the left and the other on the right, keeping them as far apart as possible, beside or just to the rear of the home theater seating area.
- Place them high up, to avoid a direct sound path to the ears of the listeners (position 1).
- If you want these speakers directly behind the seating area, make sure they are not directed at the viewers (positions 2 and 3).
- The rear speaker on the left as you face the TV is connected to the LEFT SURROUND jack on the Acoustimass® module.

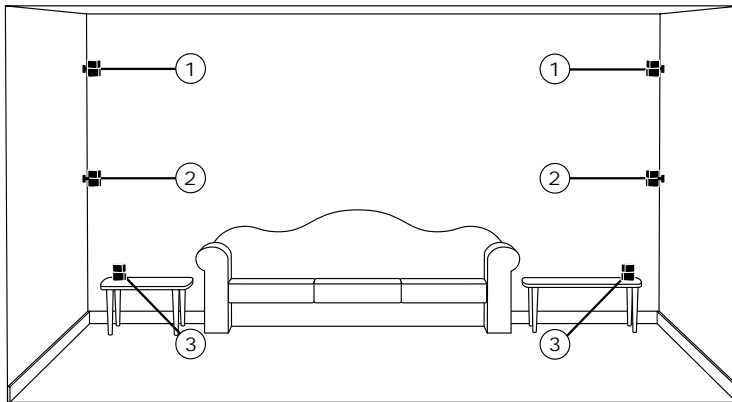

*Figure 5*

Suggested choices for surround (rear) speaker placement

### Acoustimass module

Bose® recommends putting your Acoustimass module at the same end of the room as the television monitor. To prevent interference, keep the module at least 2 feet (60 cm) from the television.

- You may hide the Acoustimass module behind or under furniture, but do not block the opening. Be sure there is at least 2 inches (5 cm) between the opening and any surface.
- If the opening faces the wall it increases the bass; if it faces away it decreases the bass. For the most bass response, place the opening 2 to 3 inches (5 to 8 cm) from a wall or corner.
- Stand the Acoustimass module vertically or horizontally (Figure 6). To stand it on the cable connection end, remove the cover by gently pulling it away.

After selecting a place for the Acoustimass module, attach the larger set of four rubber feet to the bottom surface for additional stability. The feet protect the cable connections and must be mounted when the Acoustimass module is standing on that end.

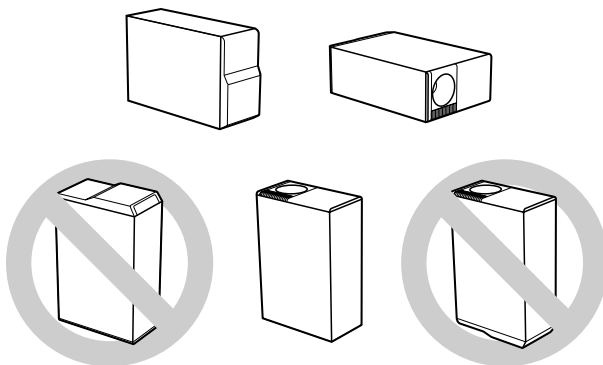

*Figure 6*

Acoustimass module position

## Connect the speakers

The supplied cables make it easy for you to connect your system. The connections at the Acoustimass® module are already made for you. There are three sets of cables, joined together to form ribbons, which may be separated or “unzipped” as much as needed to comfortably reach the speakers (Figure 7). Separate the cables as you are laying out the cable lengths.

- The 20 foot (6 m) cable with *three pairs of wires* connects the Acoustimass module to the **center, left, and right front** cube speakers.
- The 50 foot (15 m) cable with *two pairs of wires* connects the Acoustimass module to the **left and right surround** cube speakers.
- The 20 foot (6 m) cable with *five pairs of wires* connects the Acoustimass module to the **outputs on the receiver**. Separate these wires just enough to reach the connectors.

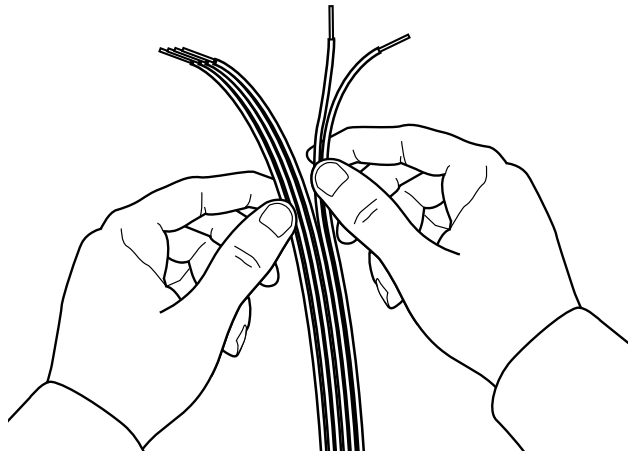

*Figure 7*

Separating cables

## Use the cable correctly

Each cable consists of insulated wire pairs attached to colored RCA connectors. The colors match the connector terminals on the cube speakers and are embossed with L, R, C, LS, and RS. The connectors have locating pins that assist you in making the correct connections (Figure 8).

- The black connector marked L goes to the left front speaker.
- The gray connector marked C goes to the center speaker.
- The black connector marked R goes to the right front speaker.
- The gray connector marked LS goes to the left surround speaker.
- The gray connector marked RS goes to the right surround speaker.

*Note:* Do not attempt to splice cables. Do not use standard RCA cables to lengthen any of the supplied cables. Call Bose® customer service for cables specifically designed for this purpose (Part Number 187092). See the customer service numbers inside the back cover.

### CAUTION:

*Before making any connections turn off your receiver or amplifier and unplug it from the outlet (AC power mains). Not doing so may result in damage to your system.*

*Never connect the cubes directly to an receiver output. Always connect the cube speakers to the Acoustimass module, then connect the Acoustimass module to the receiver.*

*Never use broken or frayed wiring, which can result in electrical shock or damage to your system.*

*The supplied cables are not intended for in-wall installation. Check local building codes or enlist a qualified installer.*



### Connect the Acoustimass® module to the center and front cube speakers

Use the 20 foot (6 m) cable with three pairs of wires to connect the Acoustimass module to the center and front cube speakers. Just press the custom RCA connectors in place.

1. Insert the gray connector marked C into the gray terminal on the center speaker.
2. Insert the black connector marked L into the black terminal on the left front speaker (to the left of the TV as you face it), and the black connector marked R to the black terminal on the right front speaker.
3. At the Acoustimass module, check to be sure the connectors are firmly inserted into the proper OUTPUT TO CUBE SPEAKER jacks.
  - a. Black L connector to the L jack.
  - b. Gray C connector to the C jack.
  - c. Black R connector to the R jack.

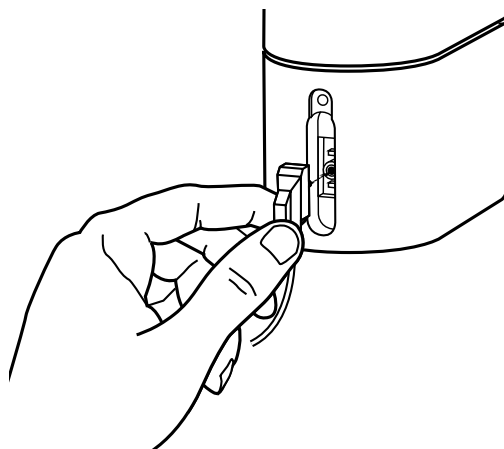

Figure 8

Making cube speaker connections

### Connect the Acoustimass module to the surround cube speakers

Use the 50 foot (15 m) cable with gray RCA connectors to join the module to the surround speakers.

1. Insert the gray connector marked LS into the gray terminal on the left surround speaker (on your left as you face the TV).
2. Insert the gray connector marked RS into the gray terminal on the right surround speaker.
3. At the Acoustimass module, make sure the gray connectors are firmly inserted into the LS and RS OUTPUT TO SPEAKER jacks.

### Connect the Acoustimass module to the receiver

Use the 20 foot (6 m) cable with five wire pairs to connect the Acoustimass module to your surround sound receiver.

1. Match the wire labels to the SPEAKER OUTPUT labels on the receiver:
  - a. L wires go to the Left Front SPEAKER OUTPUT connections.
  - b. C wires go to the Center SPEAKER OUTPUT connections.
  - c. R wires go to the Right Front SPEAKER OUTPUT connections.
  - d. LS wires go to the Left Surround (rear) SPEAKER OUTPUT connections.
  - e. RS wires go to the Right Surround (rear) SPEAKER OUTPUT connections.
2. Match the polarity on the receiver. Connect the wire pairs in phase (+ to + and – to –).
  - a. Connect each wire marked with a red collar (+) to the appropriate red (+) output.
  - b. Connect each plain wire (–) to the appropriate black (–) output.
3. At the Acoustimass module, check to make sure all RCA connectors are firmly inserted into the proper INPUT FROM RECEIVER OR AMPLIFIER jacks. Black connectors go into L and R jacks. Gray connectors go into C, LS, and RS jacks.

**CAUTION:**  
Do not connect the Acoustimass module directly to your television unless the television provides surround decoding circuitry and amplified outputs for all channels.

*Check the connections*

Check all connections from the receiver to the Acoustimass® module and the module to the cube speakers (Figure 9). Make sure all speakers are connected to the proper terminals according to their position in your room. Also make sure the two speakers with black terminal tabs are connected as front speakers.

At the receiver, check that the wires are connected in phase (+ to + and - to -). Incorrect wiring can result in a total loss of Acoustimass module output.

Be sure to correct any wiring problems before you plug your receiver in and turn it on.

**CAUTION:**  
Do not allow exposed wires to brush against each other; this could damage your receiver.

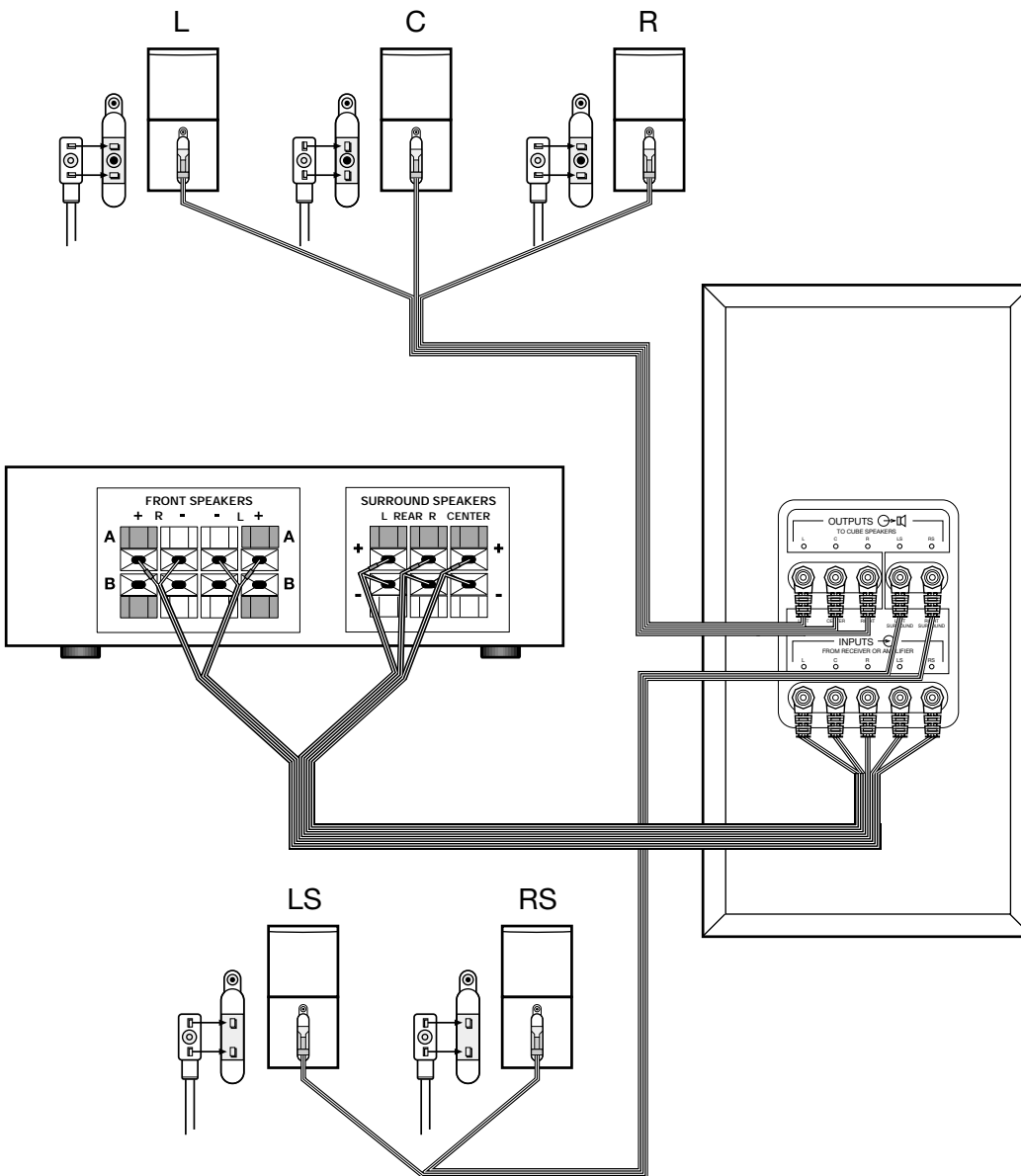

Figure 9

Completed connections

## For realistic home theater sound

Each speaker produces only the sound directed to it by the steering logic in your surround sound receiver. During a surround sound program the front and center speakers will emit sound almost constantly, while the surround speakers may be silent for periods of time.

### How to set your Pro-Logic receiver

You must set the volume levels for the front, center, and surround speakers at your receiver. For use in video applications, be sure the SURROUND SOUND *center mode* setting of your receiver is on NORMAL (Figure 10). The center channel and surround (rear) speakers have a wider response range and therefore play at a slightly lower volume. The signal levels for these speakers may need to be increased. You can adjust these levels at the receiver or with the remote control. Your receiver may have a *test tone* to help you set volume levels. If it does, follow these steps:

- Press *test tone* ON at the remote.
- Set the volume for the speakers in the following order: Left, Center, Right, Surround.
- Balance the pink noise tone for evenness among all individual speakers.

Instructions for this process vary, depending on the brand and model of receiver you are using. Follow your receiver owner's guide for testing and adjusting the balance of each speaker.

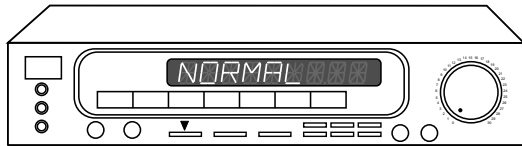

Figure 10

A Dolby Pro-Logic receiver set for NORMAL surround sound

## Bass and treble adjustments

Upholstered furniture, wall-to-wall carpets, or heavy drapes can muffle treble (high notes), making your speaker system sound bass heavy. Bare floors and walls and hard surface furniture can make your speaker system sound too shrill. After listening to your speakers, you may want to adjust the balance of bass and treble. You can use the bass and treble controls on your receiver.

## Set your Dolby AC-3 receiver correctly

Your Acoustimass-10 speakers are compatible with the output from Dolby AC-3 receivers. Take special care to set the channel output according to the specifications listed in the chart below. The cube speakers are full-range loudspeakers and must be set up as LARGE speakers on the AC-3 screen menu. An exception is the center speaker, which must be set as SMALL. Turn the subwoofer OFF. Finally, turn the LFE (low frequency effects) ON and set the crossover frequency to 200Hz.

Speaker	Setting at receiver
Left and Right Front .....	Large
Center .....	Small
Left and Right Surround .....	Large
Subwoofer .....	OFF (not used)
LFE (low frequency effects) .....	ON
Crossover frequency .....	200Hz

## Troubleshooting

If you have a problem with your Acoustimass-10 speakers, turn off your sound source and try the solutions below. If you still have a problem, contact your Bose® dealer to arrange for service. Or, to contact Bose directly, refer to the inside back cover of this guide.

<i>Problem</i>	<i>What to do</i>
System does not function at all	<ul style="list-style-type: none"> <li>• Make sure the power cord of the receiver is plugged into an operating AC wall outlet and that the unit turned on.</li> <li>• Be sure to select a source at the receiver (video, CD, tuner).</li> </ul>
No sound	<ul style="list-style-type: none"> <li>• Check the speaker connections. Turn the unit ON.</li> <li>• Increase the volume.</li> <li>• Disconnect any headphones.</li> </ul>
Sound is distorted	<ul style="list-style-type: none"> <li>• Make sure speaker cable is not damaged.</li> <li>• Reduce the volume of any external components connected to the receiver.</li> </ul>
No bass	<ul style="list-style-type: none"> <li>• Make sure the speaker connections at the receiver or amplifier are correct (+ to + and - to -). If you are using in Dolby Pro-Logic mode, check that surround sound is turned ON. If you are using AC-3 programming, verify that the settings are correct at the receiver. Be sure the source material (laser disk or broadcast programming) is Dolby AC-3 encoded.</li> </ul>
Not enough or too much bass	<ul style="list-style-type: none"> <li>• Move the Acoustimass module closer to a wall or corner to increase bass. Move it farther from a wall or corner to decrease bass.</li> </ul>
No stereo sound	<ul style="list-style-type: none"> <li>• To get the full performance benefit, your Acoustimass-10 speakers must be connected to a HiFi Stereo VCR or Stereo television.</li> </ul>

## Customer service

For additional help in solving problems, contact Bose customer service. See the inside back cover for Bose customer service offices and phone numbers.

## *Cleaning the speakers*

Wipe the cube speakers using a damp cloth. Do not use solvents or chemicals. Do not allow liquids to spill on or objects to drop into the Acoustimass module or the speaker grilles. You may vacuum the grilles carefully; the drivers are directly behind the grille cloth. No other maintenance is needed.

## *Warranty period*

Bose® Acoustimass-10 speakers are covered by a limited 5-year transferable warranty. Details of the coverage are explained on the warranty card packed with your speakers. Please fill out the information section on your card. The serial number is located on the Acoustimass module; you may choose to record it on page 2 of this guide. Then, please detach and mail the card to Bose in the pre-addressed envelope.

Bose will try to remedy any problem within the terms of your limited warranty.

## Technical information

### Features

- Direct/Reflecting® speaker technology
- Virtually Invisible® speaker design
- Acoustimass® speaker technology combined with Adaptive Energy Summing™ speaker design
- Magnetically shielded cube speakers
- Automatic system protection circuitry
- Syncom® computer quality control

### Speaker driver complement

Cube speaker arrays: two 2.50-inch Twiddler™ speakers

Acoustimass module: three 5.25-inch woofers for left and right front and surround channels

### Connectivity

Compatible with A/V receivers rated from 10 to 200 watts per front channel and 10 to 100 watts per rear channel; rated from 4 to 8 ohms

### Finish

Cube speakers: Black or Arctic white finish

Acoustimass module: Scratch-resistant black or Arctic white textured finish

### Size/Weight

Cube speaker arrays: 6 1/4"H x 3"W x 4 3/4"D (16.0 cm x 7.6 cm x 12.2 cm)  
2.1 lb (.9 kg)

Acoustimass module: 14"H x 22"W x 7 1/2"D (35.5 cm x 56 cm x 19.0 cm)  
23 lb (10.5 kg)

Packed system: 44 lb (20 kg)

### Accessories

Floor stands: FS-20B (black), FS-20W (white)

Wall brackets: WB-20B (black), WB-20W (white)







*USA*

Bose Corporation, The Mountain  
 Framingham, MA 01701-9168  
 1-800-367-4008  
 Weekdays 9 a.m. to 8 p.m.  
 Saturdays 9 a.m. to 3 p.m.  
 ET (eastern time)

*Canada*

Bose Ltd.  
 8-35 East Beaver Creek Road  
 Richmond Hill, Ontario L4B 1B3  
 1-800-444-BOSE (444-2673)  
 Weekdays 9 a.m. to 5 p.m.  
 ET (eastern time)

*European Office*

Bose B.V., Nijverheidstraat 8  
 1135 GE Edam, Nederland  
 TEL 0299-371055  
 FAX 0299-368163

*Australia*

Bose Australia, Inc., 1 Sorrell Street  
 Parramatta, N.S.W. 2150  
 TEL 02 204-6111  
 FAX 02 204-6122

*Belgique/België*

Bose N.V., Essenestraat 16  
 1740 Ternat  
 TEL 02-5826200  
 FAX 02-5823717

*Danmark*

Bose A/S, Industrivej 7, 2605 Brøndby  
 TEL 043437777  
 FAX 043437818

*Deutschland*

Bose GmbH, Max-Planck-Straße 36d  
 D-61381 Friedrichsdorf  
 TEL 06172-71040  
 FAX 06172-710419

*France*

Bose S.A., 6, rue Saint Vincent  
 78100 Saint Germain en Laye  
 TEL 01-30616363  
 FAX 01-30614105

*Ireland*

Bose Corporation  
 Carrickmacross, Co Monaghan  
 TEL 042-61988  
 FAX 042-61998

*Italia*

Bose S.p.A., Via Luigi Capucci 12  
 00147 Roma  
 TEL 06-5127641  
 FAX 06-5115438

*Japan*

Bose K.K., Shibuya YT Building  
 28-3 Maruyamacho  
 Shibuya-ku, Tokyo  
 TEL 03-5489-1054  
 FAX 03-5489-0591

*Nederland*

Bose B.V., Nijverheidstraat 8  
 1135 GE Edam  
 TEL 0299-366661  
 FAX 0299-368166

*Norge*

Bose A/S, Solheimsgt. 11  
 N-2001, Lillestrøm  
 TEL 063-817380  
 FAX 063-810819

*Österreich*

Bose Ges.m.b.H., Vienna Business Park  
 Wienerbergstrasse 7 (10.OG)  
 A-1100 Vienna  
 TEL 01-6040434  
 FAX 01-604043423

*Schweiz*

Bose AG, Rünenbergerstrasse 13  
 4460-Gelterkinden  
 TEL 061-9815544  
 FAX 061-9815502

*Sverige*

Bose A/S, Blandsädsgratan 2D  
 S-43146 Mölndal  
 TEL 031-878850  
 FAX 031-274891

*United Kingdom*

Bose Limited, Unit G2  
 Trinity Trading Estate  
 Sittingbourne, Kent ME10 2PD  
 TEL 01795-475341  
 FAX 01795-427227

*Other Locations*

Bose Service, 1 New York Avenue  
 Framingham, MA 01701-9168 USA  
 TEL (508) 229-8484  
 FAX (508) 229-3891



***BOSE***<sup>®</sup>  
*Better sound through research.*

©1996 Bose Corporation  
The Mountain  
Framingham, MA 01701-9168 USA  
JN96539 PN183644-Rev. 1