

QUICK START GUIDE • LYNSTARTVEJLEDNING • KURZANLEITUNG • BEKNOPTE HANDLEIDING
GUÍA DE INICIO RÁPIDO • PIKAOPAS • GUIDE DE DÉMARRAGE RAPIDE • GUIDA RAPIDA
GYORSISMERTETŐ • HURTIGSTARTVEILEDNING • PRZEWODNIK SZYBKIEGO STARTU
GUIA DE INÍCIO RÁPIDO • SNABBGUIDE

BOSE®

Please read and keep all safety and use instructions. • Læs og opbevar venligst alle sikkerheds- og brugsinstruktioner.

Bitte lesen Sie alle Sicherheitshinweise und Gebrauchsanleitungen durch und bewahren Sie sie auf. • Lees alle veiligheidsinstructies en de gebruiksaanwijzing door en bewaar deze.

Lea y conserve todas las instrucciones de uso y seguridad. • Lue ja säilytä kaikki turvallisuus- ja käyttöohjeet. • Lisez toutes les consignes de sécurité et les instructions d'utilisation, et conservez-les en lieu sûr.

Leggere e conservare tutte le istruzioni per la sicurezza e per l'uso. • Kérjük, olvassa el és tartsa be a biztonsági és használati utasításokat. • Les og ta vare på alle sikkerhets- og bruksinstruksjoner.

Należy zapoznać się ze wszystkimi zaleceniami dotyczącymi bezpieczeństwa oraz instrukcjami użytkowania i zachować je. • Leia e guarde todas as instruções de segurança importantes.

Läs igenom och spara alla anvisningar om säkerhet och användning.

1

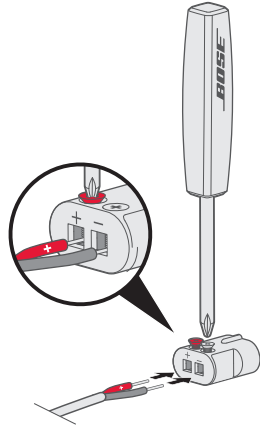

2

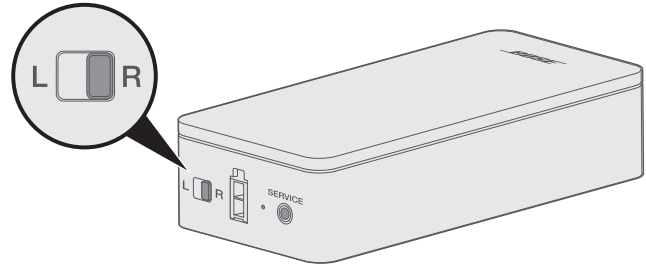

Connect your adapters

1. Insert the color-coded speaker cable wires into their corresponding terminals.
2. Turn screws to the right (clockwise) to secure the wires into the terminals.
3. Repeat steps 1 and 2 to connect your other adapter.

Identify switch settings on wireless receivers

1. Confirm that the switch on the other wireless receiver is set to **R** (right).
2. Confirm that the switch on one wireless receiver is set to **L** (left).

3

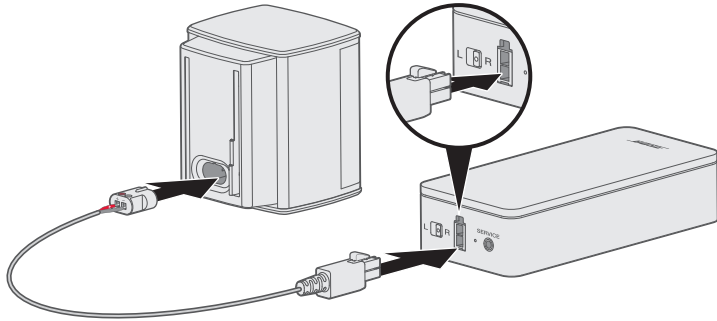

Connect your rear speakers

1. Insert the adapter into the back of the speaker.
2. Insert the two-pin connector into the wireless receiver.
3. Repeat steps 1 and 2 to set up your other speaker.

4

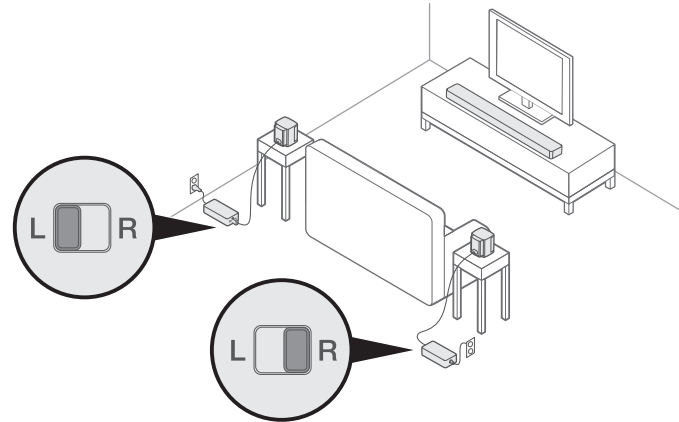

Place your rear speakers and wireless receivers

1. Facing your TV, place the speaker and **R** wireless receiver on the **right** side of the room.
2. Facing your TV, place the speaker and **L** wireless receiver on the **left** side of the room.
3. Connect to power.

5

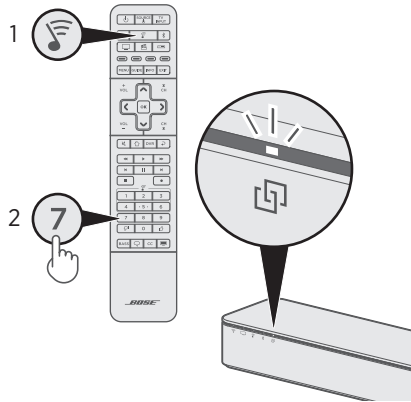

Pair with a SoundTouch® 300 soundbar

1. On the SoundTouch® 300 remote, press .
2. Press and hold **7** until blinks white.
The system emits a tone when it is paired.

6

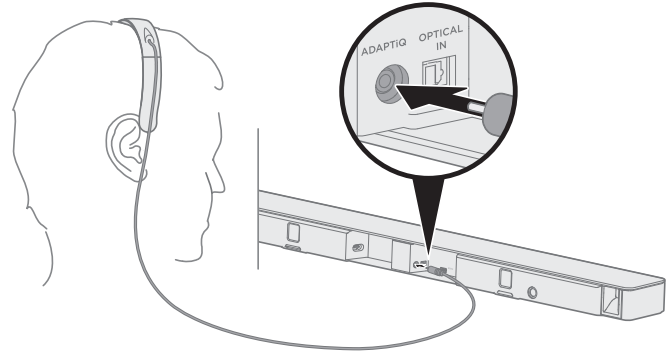



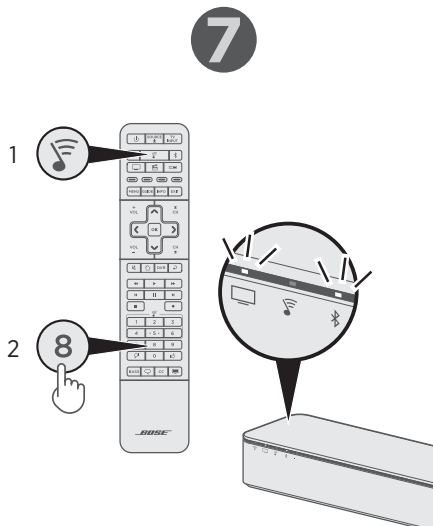

Set up ADAPTiQ®

1. Put on the ADAPTiQ® headset.
2. Plug the headset into the soundbar.



Run ADAPTiQ®

1. On the SoundTouch® 300 remote control, press .
2. Press and hold **8** until  and  on the soundbar glow green.

NOTE: To cycle through languages, press  and  on the navigation pad.

Have questions?
global.Bose.com/Support/VI300

1

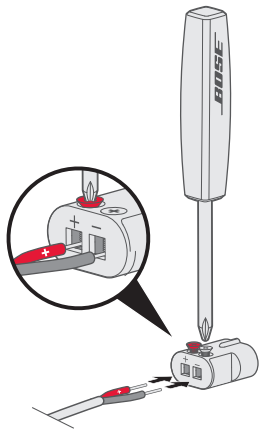

2

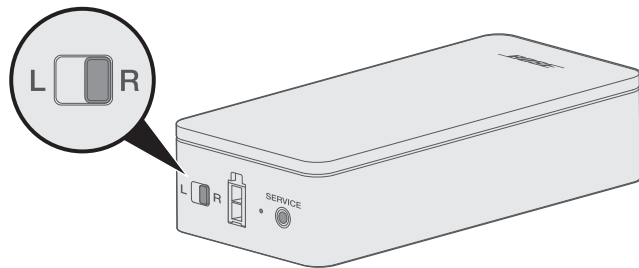

Tilslut dine adaptere

1. Sæt det farvekodede højttalerkabel i deres tilhørende terminaler.
2. Drej skrueene til højre (med uret) for at fastgøre ledningerne i terminalerne.
3. Gentag trin 1 og 2 for at tilslutte den anden adapter.

Identificer omskifterindstillinger på trådløse modtagere

1. Bekræft, at kontakten til den anden trådløse modtager er indstillet til **R** (højre).
2. Bekræft, at kontakten til en trådløs modtager er indstillet til **L** (venstre).

3

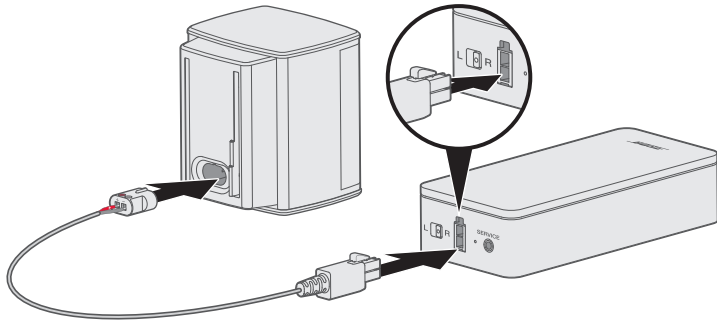

Tilslut de bagerste højttalere

1. Sæt adapteren ind bag på højttaleren.
2. Sæt det to-benede stik i den trådløse modtager.
3. Gentag trin 1 og 2 for at indstille den anden højttaler.

4

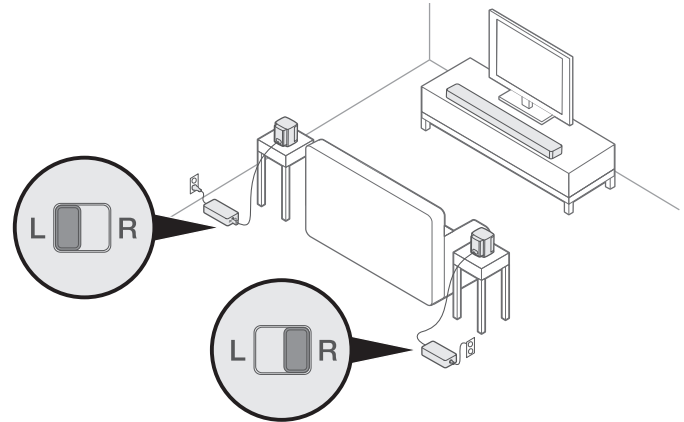



Placer bagerste højttalere og trådløse modtagere

1. Stå over for tv'et, og placer højttaleren og den trådløse modtager **R** i **højre** side af rummet.
2. Stå over for tv'et, og placer højttaleren og den trådløse modtager **L** i **venstre** side af rummet.
3. Slut til lysnettet.

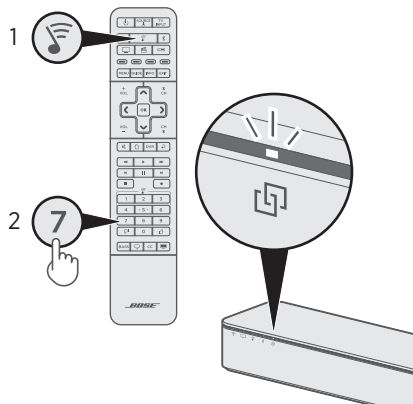
5



Par med en SoundTouch® 300 soundbar

1. Tryk på  på SoundTouch® 300-fjernbetjeningen.
2. Tryk på **7** og hold nede, indtil  blinker hvidt.
Systemet udsender en tone, når det parres.

6

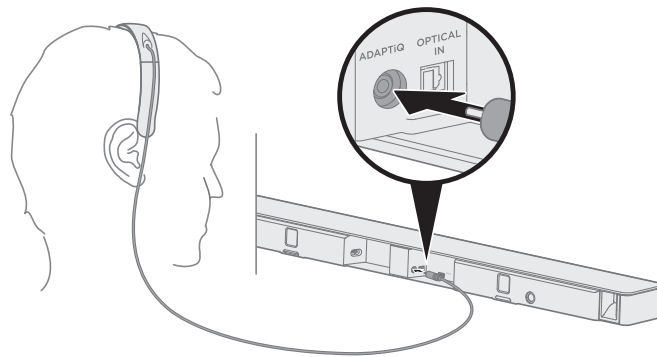



Indstilling af ADAPTiQ®

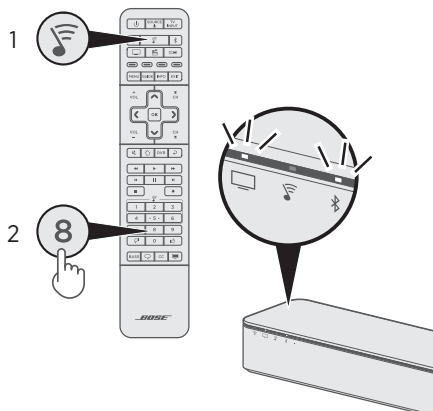

1. Tag ADAPTiQ® headsettet på.
2. Sæt headsettet i soundbaren.

7



Kør ADAPTiQ®

1. Tryk på  på SoundTouch® 300-fjernbetjeningen.
2. Tryk på **8** og hold nede, indtil  og  på soundbaren lyser grønt.

BEMÆRK: For at gå igennem de forskellige sprog skal du trykke på  og  i navigationsfeltet.

Har du spørgsmål?
[global.Bose.com/Support/VI300](https://global.bose.com/Support/VI300)

1

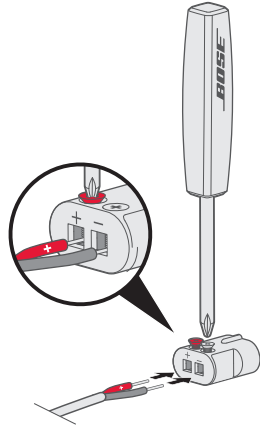

2

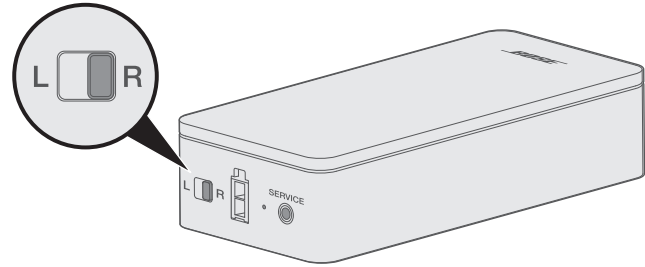

Anschließen Ihrer Adapter

1. Schließen Sie die farbkodierten Lautsprecherkabeladern an die entsprechenden Klemmen an.
2. Drehen Sie die Schrauben nach rechts (im Uhrzeigersinn), um die Adern in den Klemmen zu befestigen.
3. Wiederholen Sie die Schritte 1 und 2 mit dem anderen Adapter.

Identifizieren der Schaltereinstellungen an drahtlosen Receivern

1. Überprüfen Sie, ob der Schalter am anderen drahtlosen Receiver auf **R** (rechts) eingestellt ist.
2. Überprüfen Sie, ob der Schalter an einem drahtlosen Receiver auf **L** (links) eingestellt ist.

3

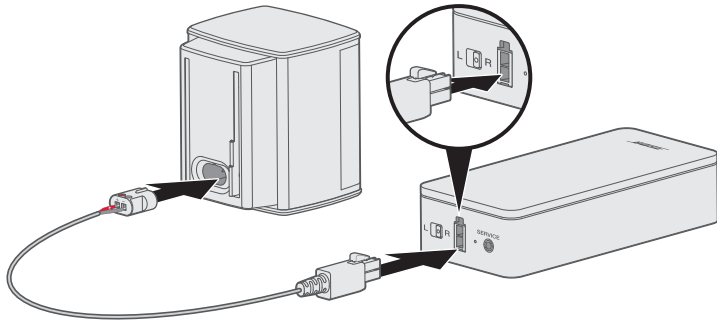

Anschließen der rückwärtigen Lautsprecher

1. Schließen Sie den Adapter an der Rückseite des Lautsprechers an.
2. Schließen Sie den zweipoligen Stecker an den drahtlosen Receiver an.
3. Wiederholen Sie die Schritte 1 und 2 zum Einrichten des anderen Lautsprechers.

4

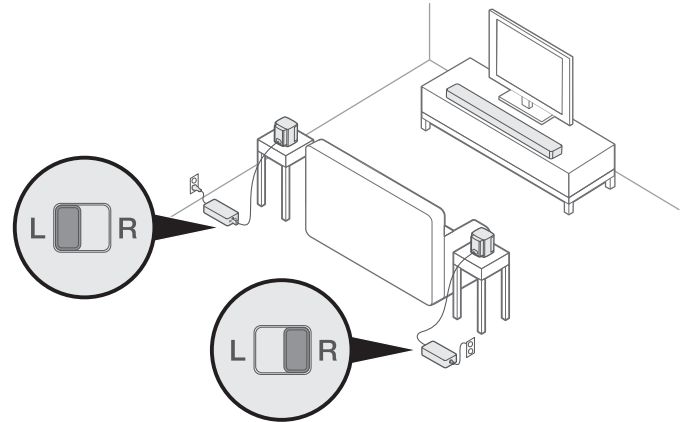

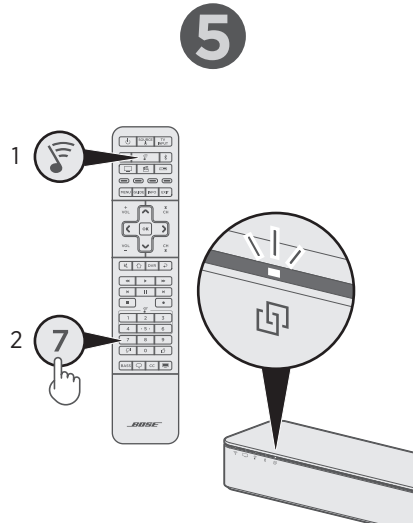

Aufstellen der rückwärtigen Lautsprecher und drahtlosen Receiver

1. Stellen Sie den Lautsprecher und den drahtlosen Receiver **R** auf der **rechten** Seite des Raums auf, wenn Sie in Richtung Fernsehgerät blicken.
2. Stellen Sie den Lautsprecher und den drahtlosen Receiver **L** auf der **linken** Seite des Raums auf, wenn Sie in Richtung Fernsehgerät blicken.
3. Anschluss an das Stromnetz.



Abstimmen mit einer SoundTouch® 300-Soundbar

1. Drücken Sie auf der Fernbedienung der SoundTouch® 300 .
2. Halten Sie **7** gedrückt, bis  weiß blinkt.
Das System gibt einen Ton ab, wenn es abgestimmt ist.

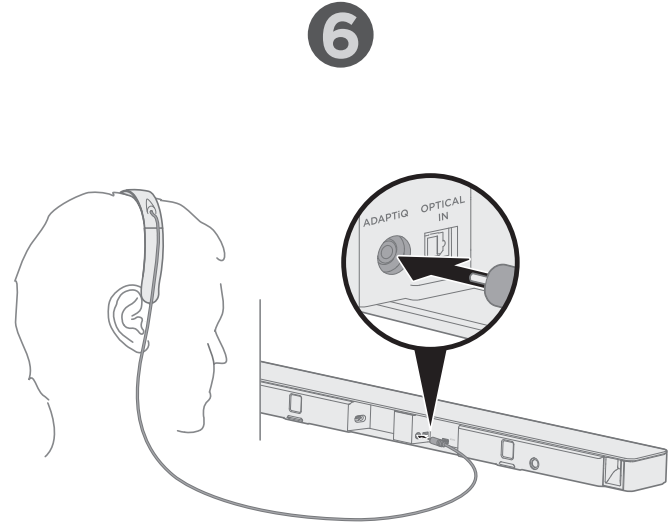

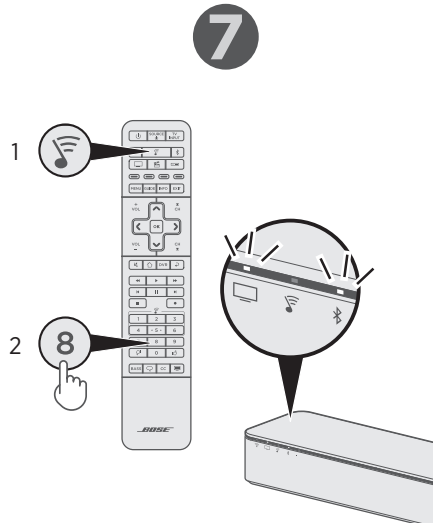

Einrichten von ADAPTiQ®

1. Setzen Sie das ADAPTiQ®-Headset auf.
2. Schließen Sie den Kopfhörer an die Soundbar an.



Ausführen von ADAPTiQ®

1. Drücken Sie auf der SoundTouch® 300-Fernbedienung .
2. Halten Sie **8** gedrückt, bis  und  an der Soundbar grün leuchten.

HINWEIS: Halten Sie zum Umschalten zwischen den Sprachen  und  auf dem Navigationsfeld gedrückt.

Haben Sie Fragen?
global.bose.com/Support/VI300

1

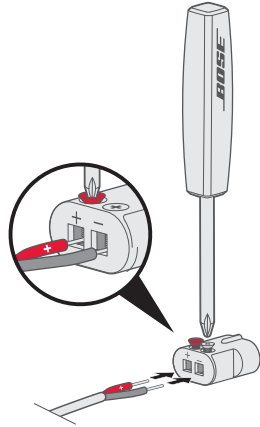

De adapters aansluiten

1. Steek de kleurgecodeerde draden van de luidsprekerkabel in de overeenkomstige aansluitpunten.
2. Draai de schroeven naar rechts om de draden in de aansluitpunten vast te zetten.
3. Herhaal de stappen 1 en 2 om de andere adapter aan te sluiten.

2

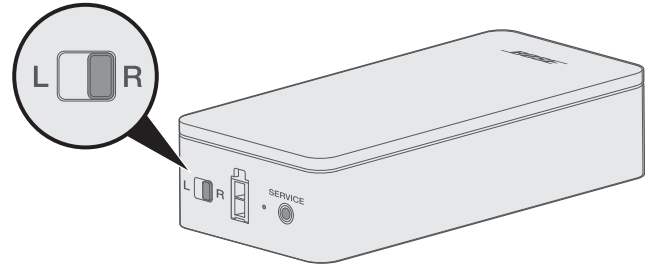

De instelling van de schakelaars op de draadloze ontvangers controleren

1. Zorg dat de schakelaar op de ene draadloze ontvanger is ingesteld op **R** (rechts).
2. Zorg dat de schakelaar op de andere draadloze ontvanger is ingesteld op **L** (links).

3

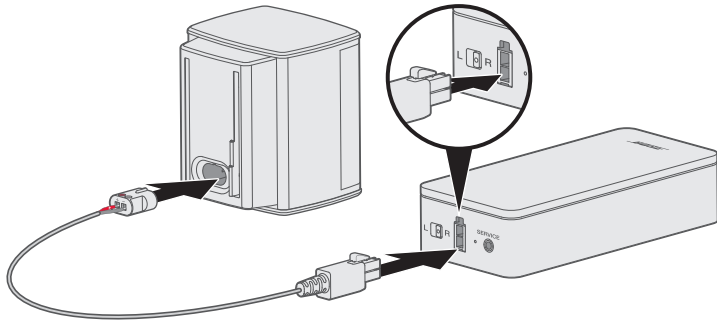

De achterste luidsprekers aansluiten

1. Steek de adapter in de achterkant van de luidspreker.
2. Steek de tweepinsstekker in de draadloze ontvanger.
3. Herhaal de stappen 1 en 2 om de andere luidspreker aan te sluiten.

4

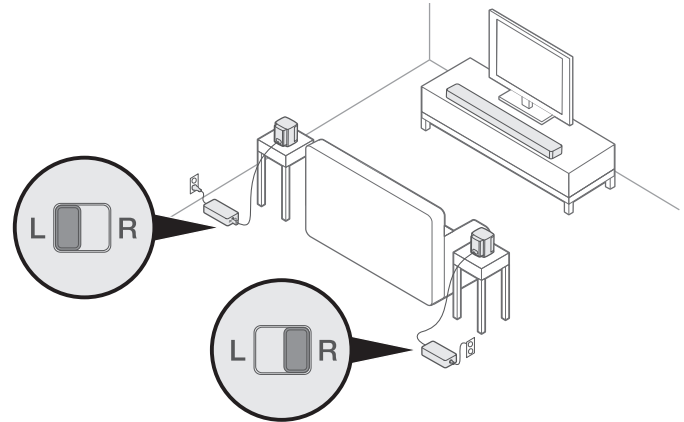

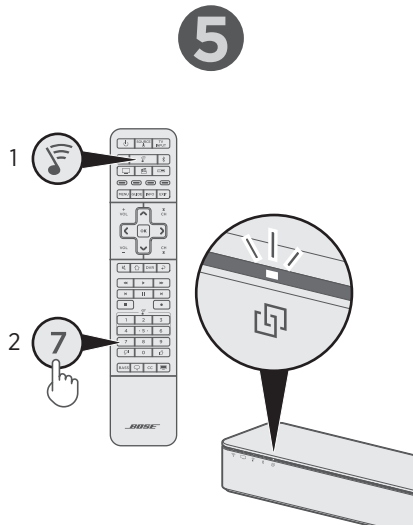

De achterste luidsprekers en draadloze ontvangers plaatsen

1. Ga met je gezicht naar de tv staan en zet de luidspreker met de draadloze ontvanger **R** aan de **rechter**kant van de kamer.
2. Ga met je gezicht naar de tv staan en zet de luidspreker met de draadloze ontvanger **L** aan de **linker**kant van de kamer.
3. Sluit op het lichtnet aan.



Koppelen met een SoundTouch® 300 soundbar

1. Druk op  op de afstandsbediening van de SoundTouch® 300.
2. Houd **7** ingedrukt totdat  wit knippert.
Het systeem laat een toon horen wanneer het is gekoppeld.

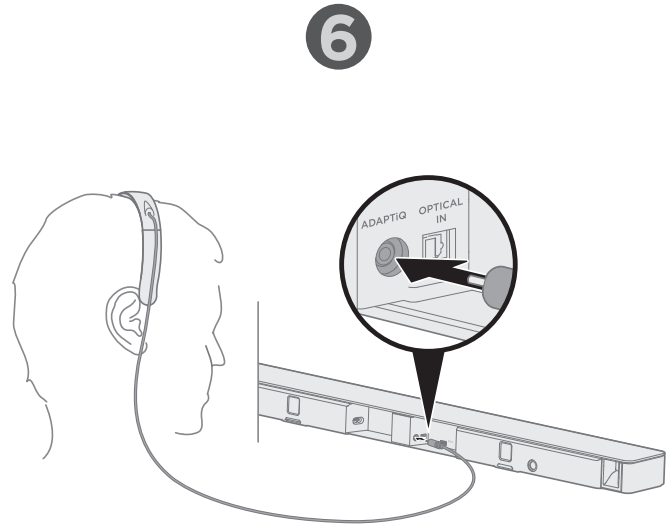

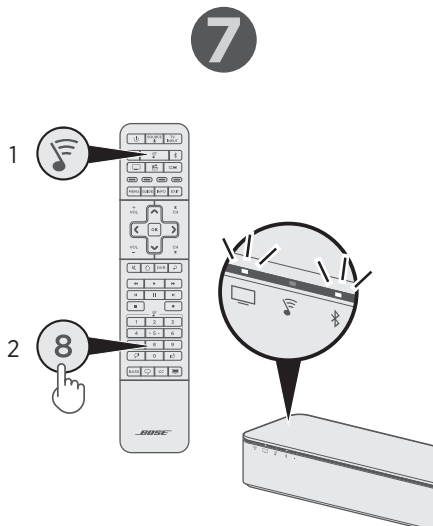

ADAPTiQ® instellen

1. Zet de ADAPTiQ®-headset op.
2. Sluit de headset op de soundbar aan.



ADAPTiQ® starten

1. Druk op  op de afstandsbediening van de SoundTouch® 300.
2. Houd **8** ingedrukt totdat  en  op de soundbar groen oplichten.

OPMERKING: Je kunt de talen doorlopen door te drukken op  en  op het navigatiepad.

Heb je vragen?
global.Bose.com/Support/VI300

1

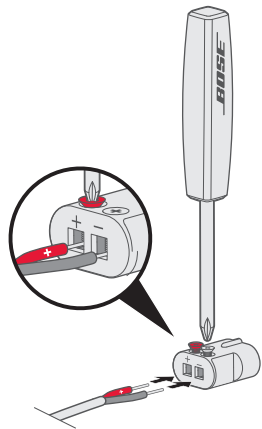

2

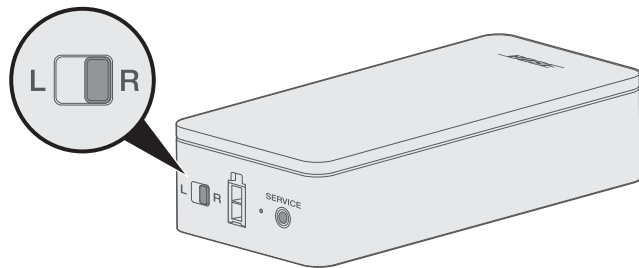

Conecte los adaptadores

1. Inserte los cables de del cable del altavoz con código de color en las terminales correspondientes.
2. Gire los tornillos hacia la derecha para asegurar los cables en las terminales.
3. Repita los pasos 1 y 2 para conectar el otro adaptador.

Identifique la configuración de los interruptores en los receptores inalámbricos

1. Confirme que el interruptor en el otro receptor inalámbrico esté ajustado a **R** (derecho).
2. Confirme que el interruptor en uno de los receptores inalámbricos esté ajustado a **L** (izquierdo).

3

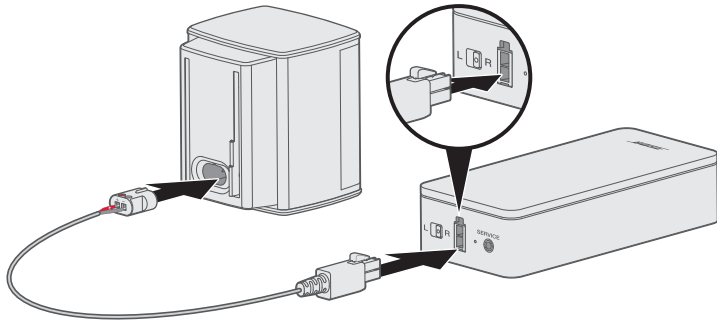

Conecte los altavoces traseros

1. Inserte el adaptador en la parte posterior del altavoz.
2. Enchufe el conector de dos pines en el receptor inalámbrico.
3. Repita los pasos 1 y 2 para configurar el otro altavoz.

4

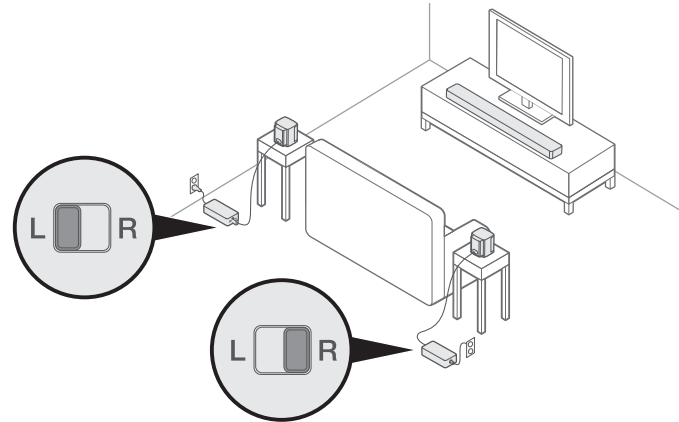

Coloque los altavoces traseros y receptores inalámbricos.

1. Mirando el televisor, coloque el altavoz y el receptor inalámbrico **R** en el lado **derecho** de la habitación.
2. Mirando el televisor, coloque el altavoz y el receptor inalámbrico **L** en el lado **izquierdo** de la habitación.
3. Conexión a la alimentación

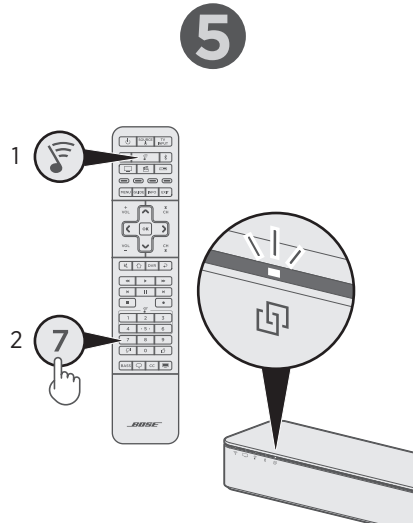

Emparejamiento con una barra de sonido SoundTouch® 300

1. En el control remoto del SoundTouch® 300, presione .
2. Mantenga presionado **7** hasta que parpadee en blanco.
El sistema emite un sonido cuando se empareja.

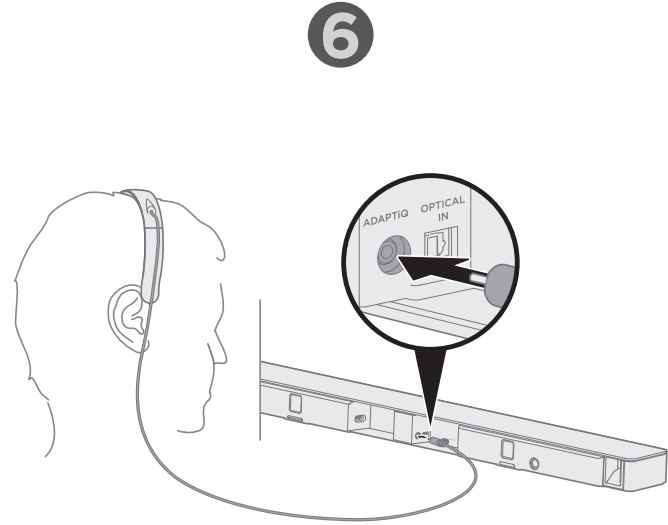



Configure ADAPTiQ®

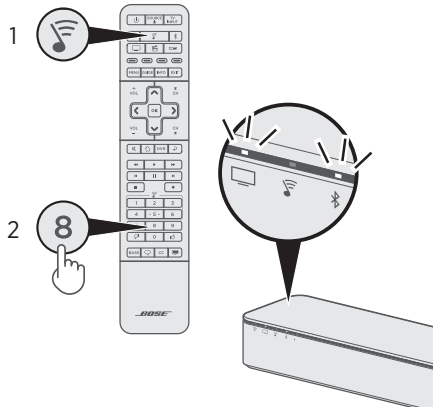

1. Colóquese el auricular ADAPTiQ®.
2. Enchufe los auriculares en la barra de sonido.

7



Ejecute ADAPTiQ®

1. En el control remoto SoundTouch® 300, presione .
2. Mantenga presionado **8** hasta que  y  en la barra de sonido se iluminen en verde.

NOTA: Para cambiar entre los distintos idiomas, presione  y  en el panel de navegación.

¿Tiene preguntas?
global.Bose.com/Support/VI300

1

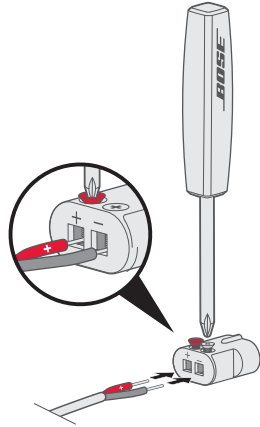

2

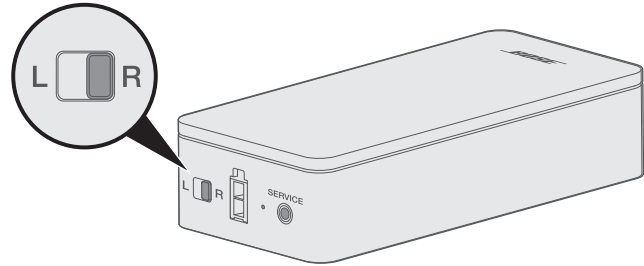

Liitä sovittimet

1. Työnnä kaiutinjohton värikoodatut johtimet oikeisiin liittimiin.
2. Kiinnitä johtimet liittimiin kiertämällä ruuveja oikealle (myötäpäivään).
3. Liitä toinen sovitin toistamalla vaiheet 1 ja 2.

Oikeat kytkinasetukset langattomissa vastaanottimissa

1. Aseta ensimmäisen langattoman vastaanottimen kytkin asentoon **R** (oikealle).
2. Aseta toisen langattoman vastaanottimen kytkin asentoon **L** (vasemmalle).

3

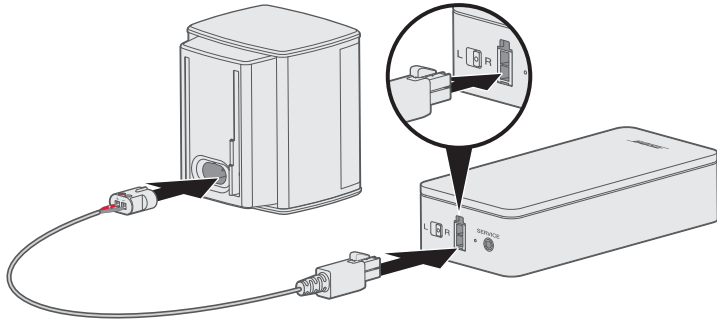

Liitä takakaiuttimet

1. Työnnä sovitin kaiuttimen takaosaan.
2. Työnnä kaksinastainen liitin langattomaan vastaanottimeen.
3. Asenna toinen kaiutin toistamalla vaiheet 1 ja 2.

4

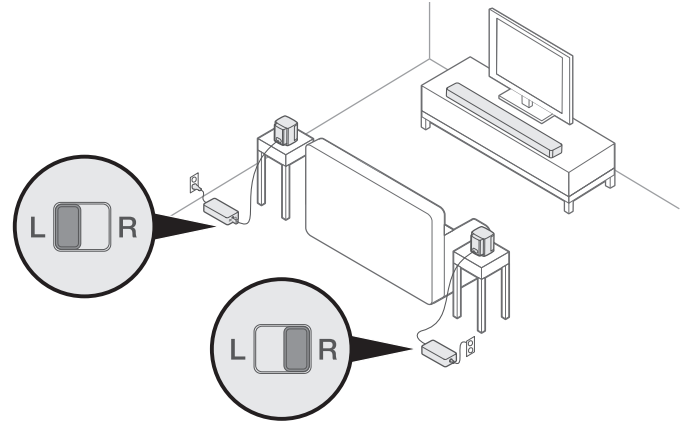

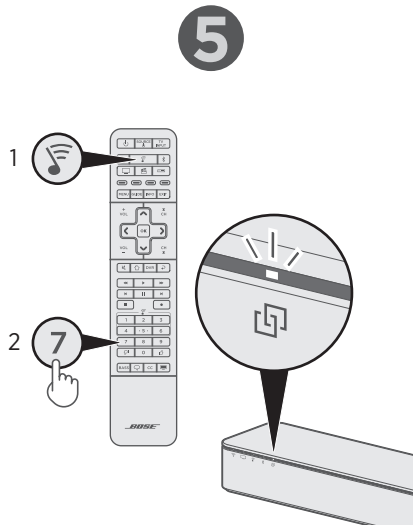

Sijoita takakaiuttimet ja langattomat vastaanottimet

1. Aseta kaiutin ja **R**-merkitty langaton vastaanotin huoneen **oikealle** puolelle siten, että ne ovat televisiota kohti.
2. Aseta kaiutin ja **L**-merkitty langaton vastaanotin huoneen **vasemmalle** puolelle siten, että ne ovat televisiota kohti.
3. Kytke virta.



Muodosta laitepari SoundTouch® 300 soundbarin kanssa

1. Paina SoundTouch® 300 -kaukosäätimessä .
2. Pidä **7** painettuna, kunnes  alkaa vilkkua valkoisena.
Järjestelmästä kuuluu äänimerkki, kun laitepari on muodostettu.

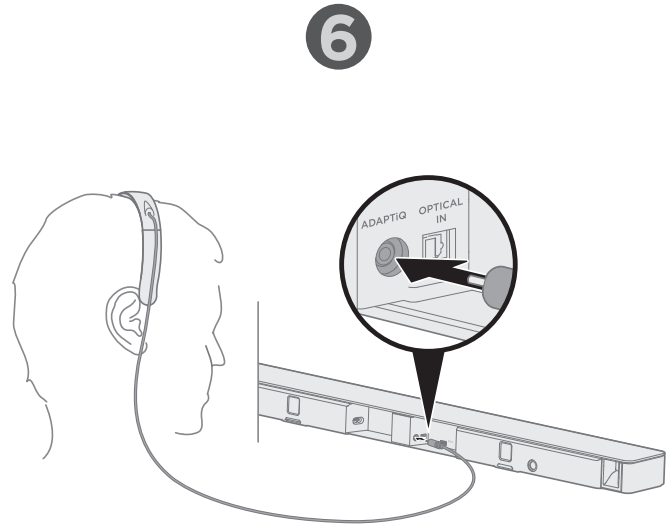



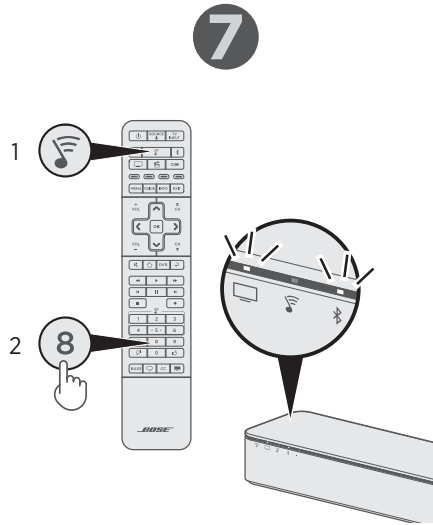

Valmistele ADAPTiQ®

1. Aseta ADAPTiQ®-kuulokkeet päähäsi.
2. Liitä kuulokkeet soundbariin.



Suorita ADAPTiQ®

1. Paina SoundTouch® 300 -kaukosäätimessä .
2. Pidä **8** painettuna, kunnes soundbarin  ja  syttyvät vihreinä.

HUOMAA: Voit selata kieliä painamalla siirtymistyynyn painikkeita  ja .

Onko sinulla kysyttävää?
global.Bose.com/Support/VI300

1

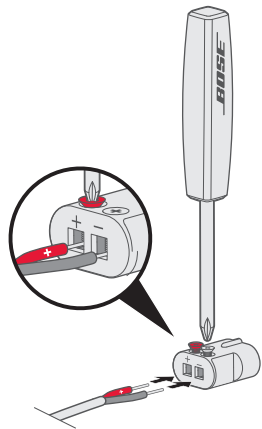

2

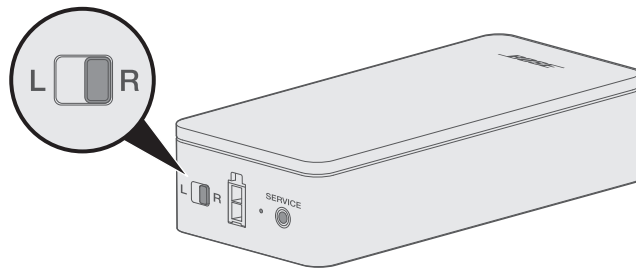

Raccordement de vos adaptateurs

1. Insérez les fils du câble d'enceinte de couleur dans les bornes correspondantes.
2. Serrez les vis dans le sens des aiguilles d'une montre (vers la droite) pour fixer les fils aux bornes.
3. Répétez les étapes 1 et 2 pour raccorder l'autre adaptateur.

Identification des réglages d'interrupteur sur les récepteurs sans fil

1. Vérifiez que l'interrupteur sur l'autre récepteur sans fil est positionné sur **R** (droite).
2. Vérifiez que l'interrupteur sur le récepteur sans fil est positionné sur **L** (gauche).

3

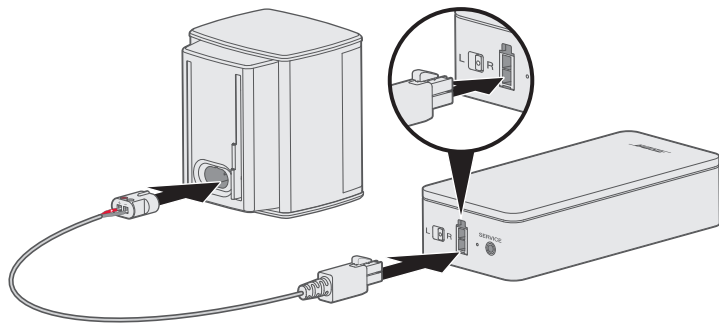

Raccordement des enceintes arrière

1. Insérez l'adaptateur à l'arrière de l'enceinte.
2. Raccordez le connecteur à deux broches au récepteur sans fil.
3. Répétez les étapes 1 et 2 pour raccorder l'autre enceinte.

4

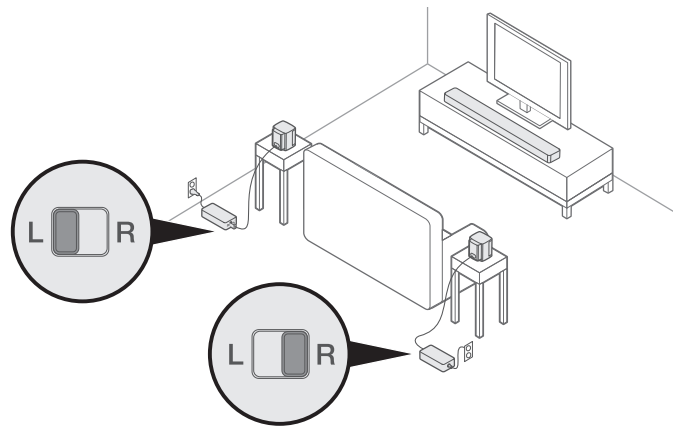

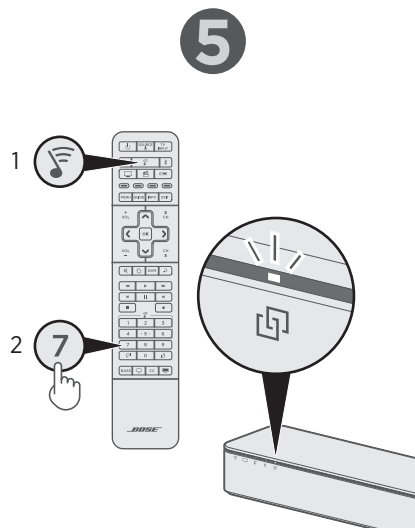

Installation des enceintes arrière et des récepteurs sans fil

1. Installez l'enceinte et le récepteur sans fil **R** à **droite** de la pièce, face à votre téléviseur.
2. Installez l'enceinte et le récepteur sans fil **L** à **gauche** de la pièce, face à votre téléviseur.
3. Raccordez l'enceinte à la prise secteur.



Jumelage avec une barre de son SoundTouch® 300

1. Sur la télécommande de la barre de son SoundTouch® 300, appuyez sur la touche .
2. Maintenez enfoncée la touche **7** jusqu'à ce que le symbole  clignote en blanc.

Le système émet une tonalité lorsque le jumelage est terminé.

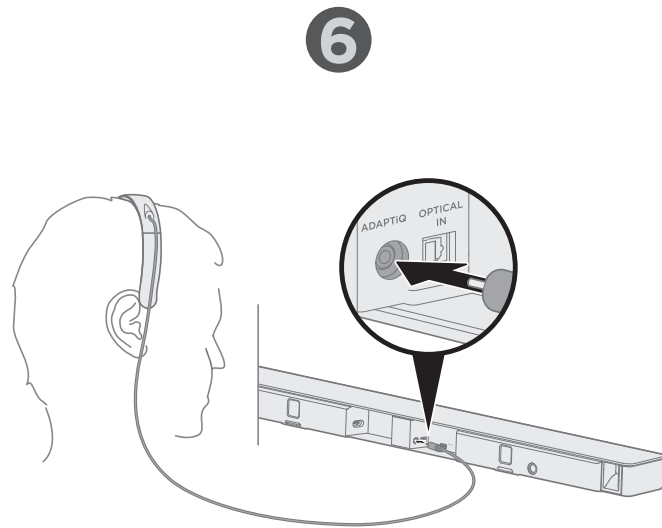



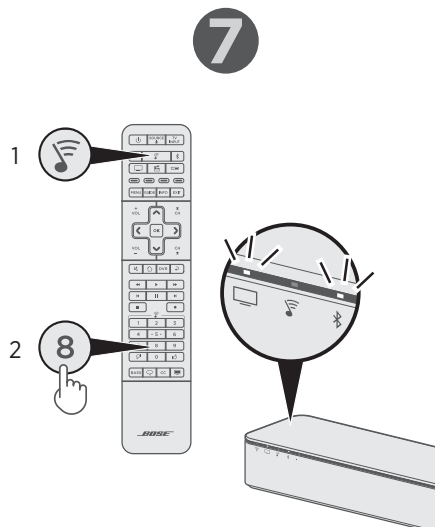

Configuration de l'étalonnage audio ADAPTiQ®

1. Placez le casque ADAPTiQ® sur votre tête.
2. Branchez-le à la barre de son.



Exécution de l'étalonnage audio ADAPTiQ®

1. Sur la télécommande de la SoundTouch® 300, appuyez sur la touche .
2. Appuyez sur la touche **8** jusqu'à ce que les indications  et  clignotent en vert sur la barre de son.

REMARQUES : pour parcourir les langues, appuyez sur les touches  et  du pavé de navigation.

Des questions ?
global.Bose.com/Support/VI300

1

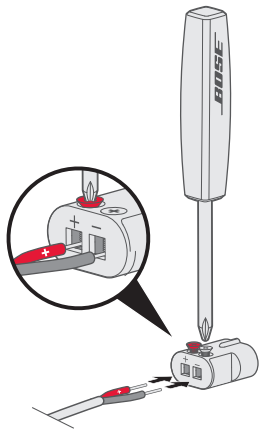

2

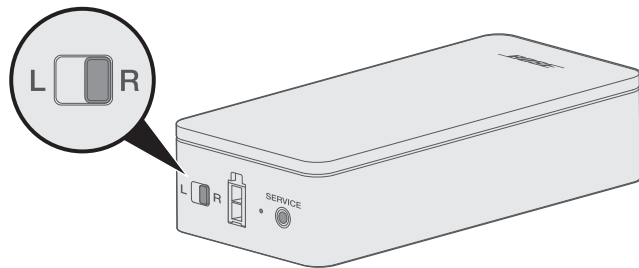

Collegare i diffusori

1. Inserire i fili colorati del cavo del diffusore nei terminali di colore corrispondente.
2. Girare le viti a destra (in senso orario) per fissare i fili nei terminali.
3. Ripetere i passaggi 1 e 2 per collegare l'altro adattatore.

Identificare le impostazioni degli interruttori sui ricevitori wireless

1. Verificare che l'interruttore su uno dei ricevitori wireless sia in posizione **R** (right, destra).
2. Verificare che l'interruttore sull'altro ricevitore wireless sia in posizione **L** (left, sinistra).

3

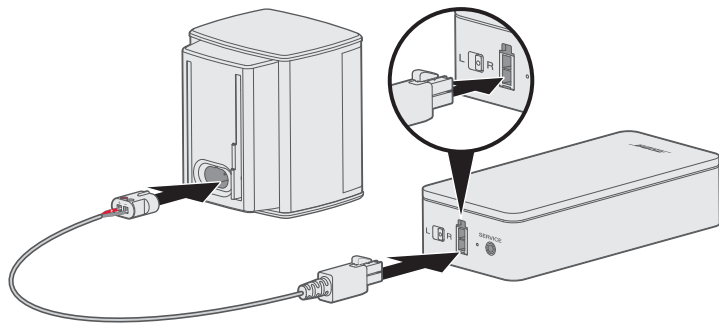

Collegare i diffusori posteriori

1. Inserire l'adattatore nel retro del diffusore.
2. Inserire il connettore a due pin nel ricevitore wireless.
3. Ripetere i passaggi 1 e 2 per configurare l'altro diffusore.

4

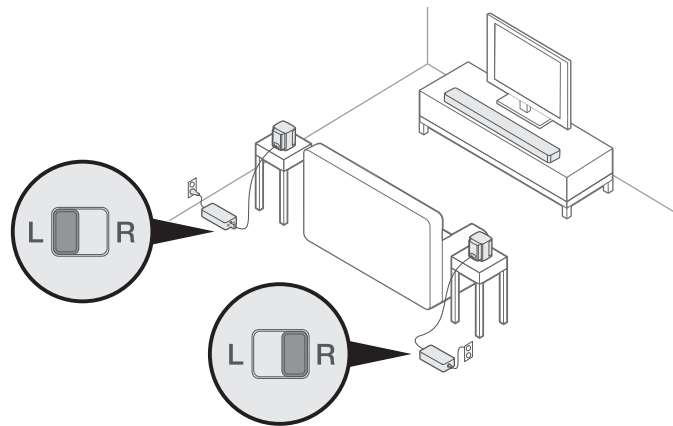

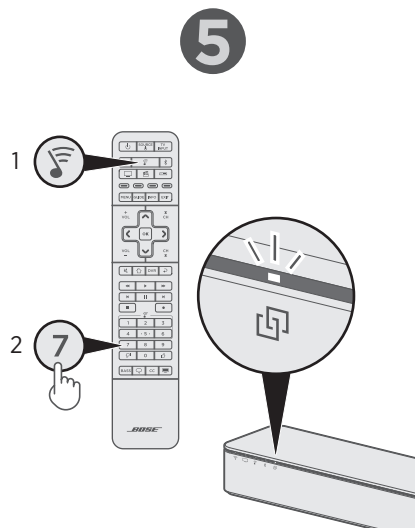

Collocare i diffusori posteriori e i ricevitori wireless

1. Stando di fronte al televisore, collocare il diffusore e il ricevitore wireless **R** nella parte **destra** della stanza.
2. Stando di fronte al televisore, collocare il diffusore e il ricevitore wireless **L** nella parte **sinistra** della stanza.
3. Collegare all'alimentazione.



Accoppiare con una soundbar SoundTouch® 300

1. Sul telecomando di SoundTouch® 300, premere .
2. Premere e tenere premuto **7** finché  non lampeggia con luce bianca.

Il sistema emette un segnale acustico quando viene accoppiato.

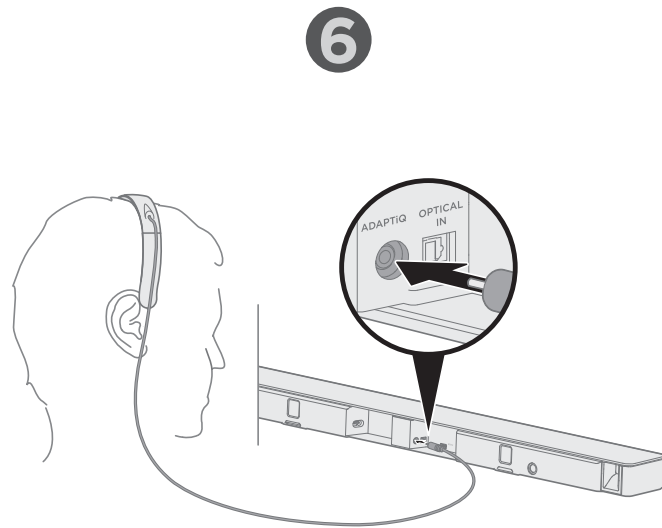

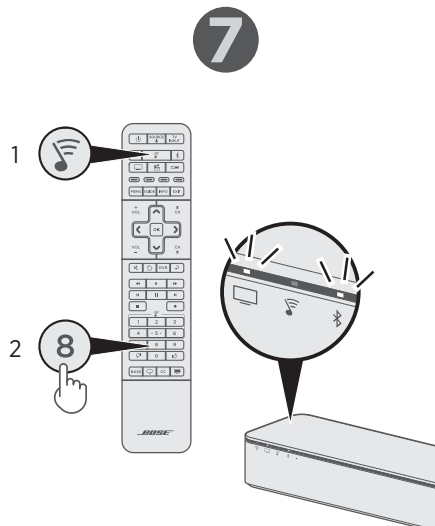

Configurare ADAPTiQ®

1. Indossare le cuffie ADAPTiQ®.
2. Collegare le cuffie alla soundbar.



Eseguire ADAPTiQ®

1. Sul telecomando di SoundTouch® 300, premere .
2. Premere e tenere premuto **8** finché i simboli  e  sulla soundbar non lampeggiano in verde.

NOTA: per scorrere le lingue disponibili, premere  e  sul pad di navigazione.

Domande?
global.bose.com/Support/VI300

1

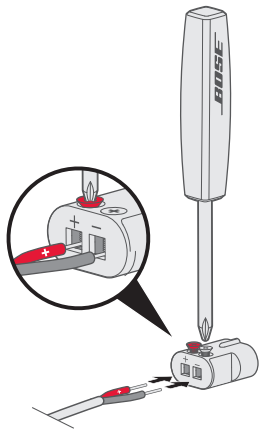

Csatlakoztassa az adaptereket

1. A színekkel jelölt hangszórkábeleket dugja be a megfelelő csatlakozóvégekbe.
2. A csavarokat jobbra (az óramutató járásával megegyező irányba) forgatva erősítse a kábeleket a csatlakozóvégekbe.
3. A többi adapter csatlakoztatásához ismételje meg az 1. és 2. lépést.

2

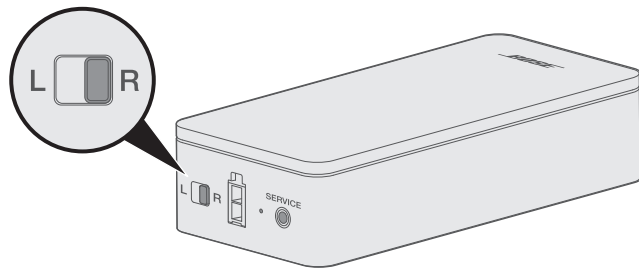

Ellenőrizze a vezeték nélküli vevőegység kapcsolóbeállításait

1. Győződjön meg róla, hogy az egyik vezeték nélkül vevőegység kapcsolója **R** (jobb) állásban van.
2. Győződjön meg róla, hogy a másik vezeték nélkül vevőegység kapcsolója **L** (bal) állásban van.

3

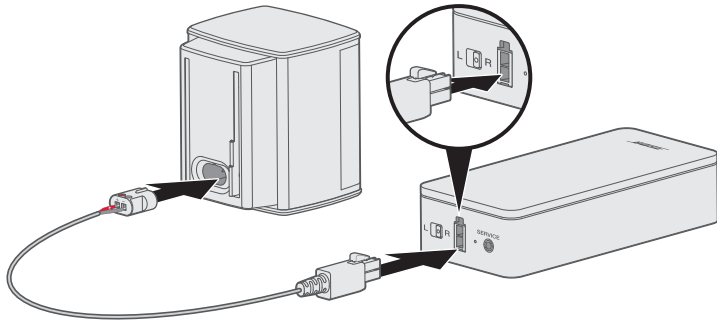

Csatlakoztassa a hátsó hangszórókat

1. Dugja az adaptert a hangszóró hátuljába.
2. Dugja a kéttűs csatlakozót a vezeték nélküli vevőegységbe.
3. A többi hangszóró beállításához ismételje meg az 1. és 2. lépést.

4

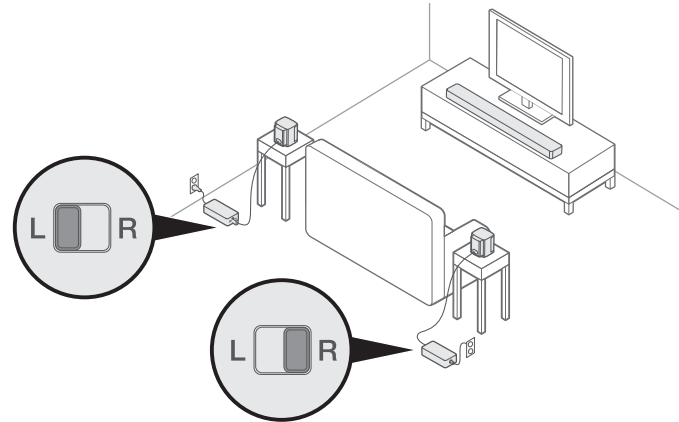

Helyezze el a hátsó hangszórókat és a vezeték nélküli vevőket

1. Álljon szembe a tévével, és helyezze a hangszórót és az **R** jelzésű vezeték nélküli vevőegységet a szoba **jobb** oldali részébe.
2. Álljon szembe a tévével, és helyezze a hangszórót és az **L** jelzésű vezeték nélküli vevőegységet a szoba **bal** oldali részébe.
3. Csatlakoztassa az áramforráshoz.

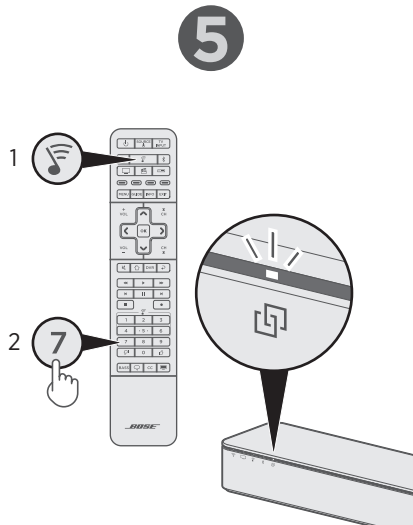

Párosítás a SoundTouch® 300 hangsugárzóval

1. A SoundTouch® 300 távvezérlőjén nyomja meg a gombot.
2. Tartsa lenyomva a **7** gombot, amíg a jelzőfény fehéren nem villog. A párosítás megtörténtét a rendszer egy hangjelzéssel kíséri.

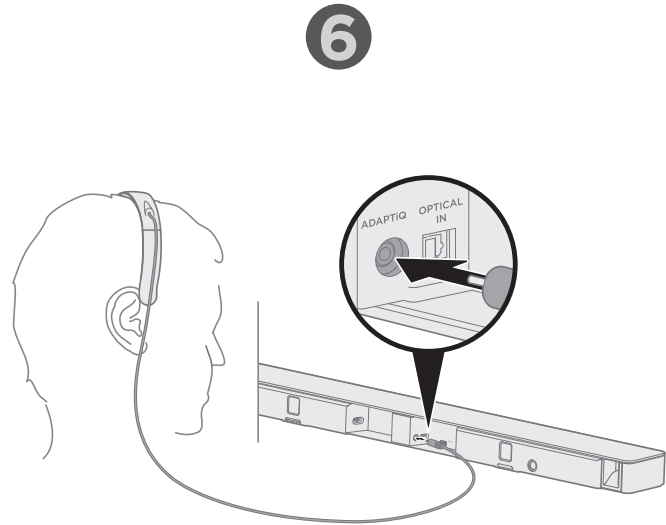

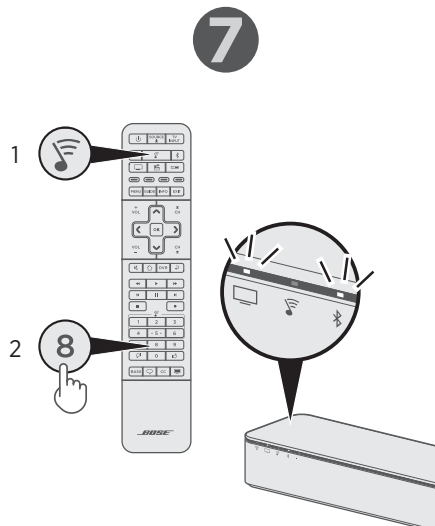

Készítse elő az ADAPTiQ® alkalmazást

1. Helyezze fel az ADAPTiQ® fejhallgatót.
2. Dugja be a fejhallgatót a hangsugárzóba.



Futtassa le az ADAPTiQ® alkalmazást

1. A SoundTouch® 300 távvezérlőjén nyomja meg a 🎵 gombot.
2. Nyomja le, és tartsa lenyomva a **8** gombot, amíg a hangszugárzó  és  gombja zölden nem világít.

MEGJEGYZÉS: A nyelvek közötti váltáshoz nyomogassa a navigációs panel  és  gombját.

Kérdései vannak?
global.Bose.com/Support/VI300

1

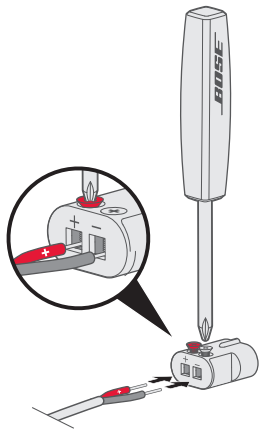

2

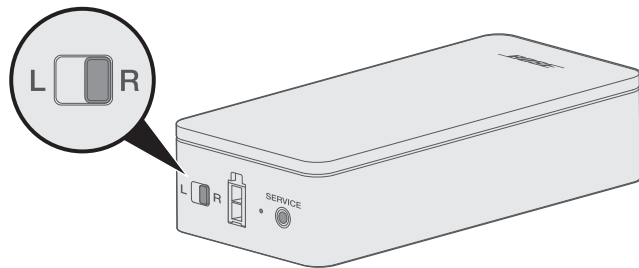

Koble til adapterne

1. Sett de fargekodete høyttalerkablene inn i sine tilsvarende terminaler.
2. Vri skruene mot høyre (med klokken) for å feste kablene til terminalene.
3. Gjenta trinn 1 og 2 for å koble til den andre adapteren.

Identifisere bryterinnstillinger på trådløse mottakere

1. Bekreft at bryteren på den andre trådløse mottakeren er satt til **R** (høyre).
2. Bekreft at bryteren på den første trådløse mottakeren er satt til **L** (venstre).

3

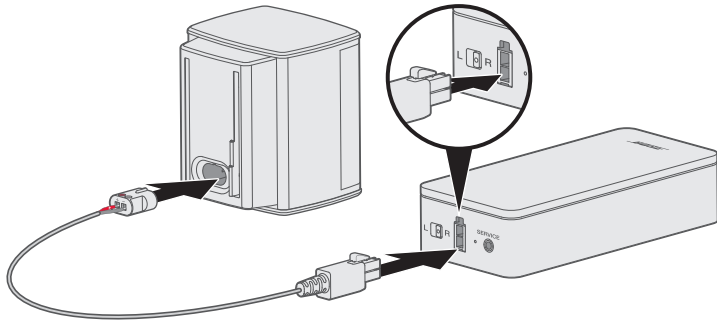

Koble til høyttalerne

1. Sett adapteren inn på baksiden av høyttaleren.
2. Sett topinnerskontakten inn i den trådløse mottakeren.
3. Gjenta trinn 1 og 2 for å koble til den andre høyttaleren.

4

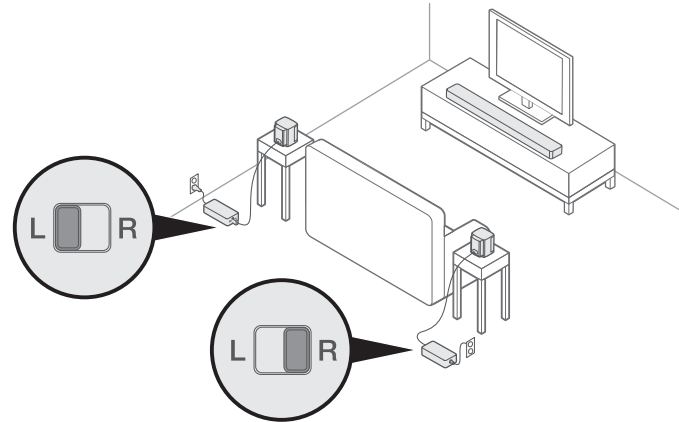

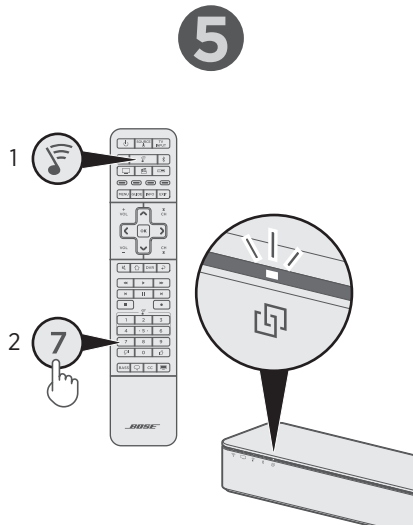

Plassere bakhøyttalerne og de trådløse mottakerne

1. Plasser høyttaleren rettet mot TV-en og den trådløse **R**-mottakeren til **høyre** i rommet.
2. Plasser høyttaleren rettet mot TV-en og den trådløse **L**-mottakeren til **venstre** i rommet.
3. Koble til strøm.



Koble sammen med en SoundTouch® 300-lydplanke

1. Trykk  på SoundTouch® 300-fjernkontrollen.
2. Trykk og hold **7** til  blinker hvitt.
Systemet spiller av en tone når den er koblet sammen.

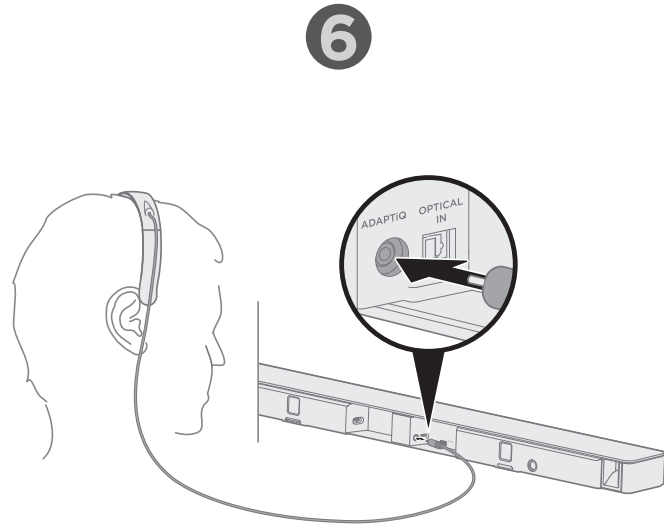

Konfigurere ADAPTiQ®

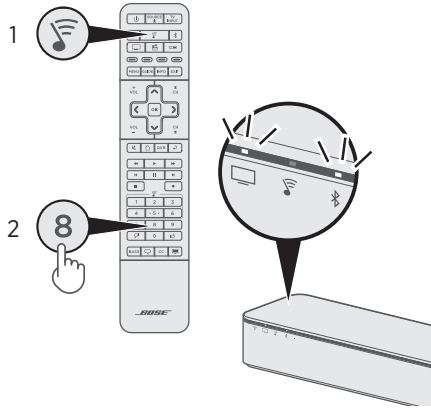

1. Ta på deg ADAPTiQ®-hodetelefonene.
2. Plugg hodetelefonene inn i lydplanken.

7



Kjøre ADAPTiQ®

1. Trykk  på SoundTouch® 300-fjernkontrollen.
2. Trykk og hold **8** til  og  på lydplanken lyser grønt.

MERK: Du går gjennom språkene ved å trykke  og  på navigasjonsplaten.

Har du spørsmål?
global.bose.com/Support/VI300

1

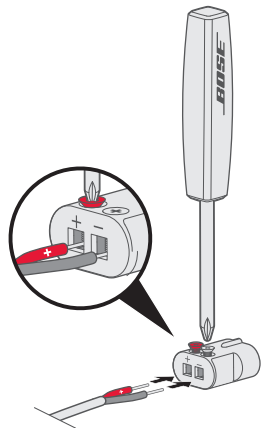

2

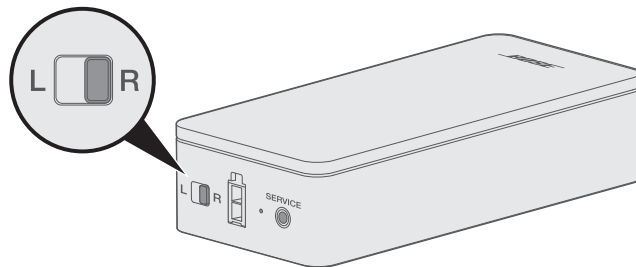

Podłączanie adapterów

1. Włóż oznaczone kolorystycznie przewody kabla głośnikowego do odpowiednich zacisków.
2. Przekręć wkręty w prawo (w kierunku ruchu wskazówek zegara), aby zamocować przewody w zaciskach.
3. Powtórz kroki 1 i 2, aby podłączyć drugi adapter.

Sprawdzanie ustawień przełącznika na odbiornikach bezprzewodowych

1. Sprawdź, czy przełącznik na jednym z odbiorników bezprzewodowych znajduje się w położeniu prawym (**R**).
2. Sprawdź, czy przełącznik na drugim z odbiorników bezprzewodowych znajduje się w położeniu lewym (**L**).

3

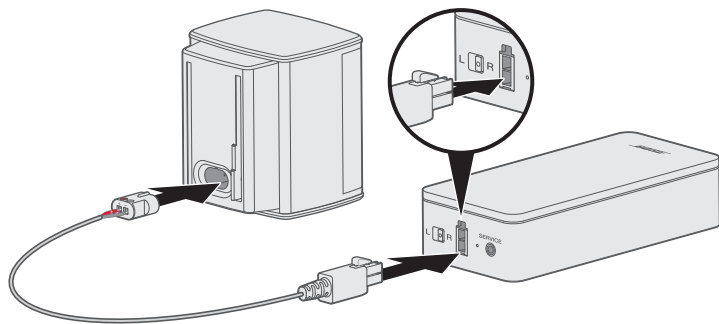

Podłączanie głośników tylnych

1. Włóż adapter do gniazda w tylnej części głośnika.
2. Włóż dwustykowe złącze do gniazda w odbiorniku bezprzewodowym.
3. Powtórz kroki 1 i 2, aby podłączyć drugi głośnik.

4

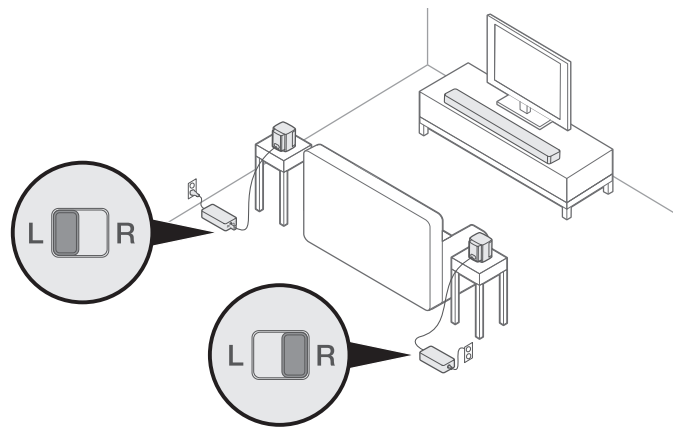

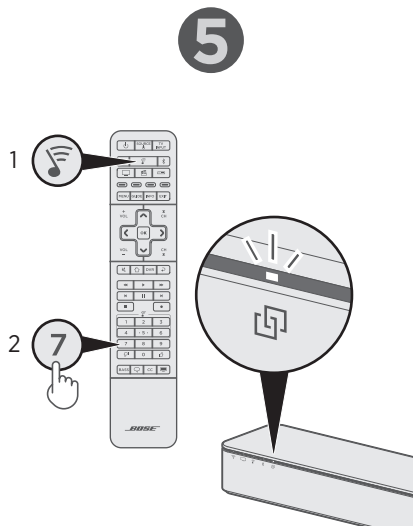

Ustawianie głośników tylnych i odbiorników bezprzewodowych

1. Umieść głośnik i odbiornik bezprzewodowy **R** z **prawej** strony pokoju, tak by głośnik był skierowany przodem w kierunku telewizora.
2. Umieść głośnik i odbiornik bezprzewodowy **L** z **lewej** strony pokoju, tak by głośnik był skierowany przodem w kierunku telewizora.
3. Podłącz zasilanie.



Parowanie z listwą dźwiękową SoundTouch® 300

1. Na pilocie zdalnego sterowania listwą SoundTouch® 300 naciśnij przycisk .
2. Naciśnij przycisk **7** i przytrzymaj go, aż wskaźnik  zacznie migać na biało.
Po zakończeniu parowania system wyemituje sygnał dźwiękowy.

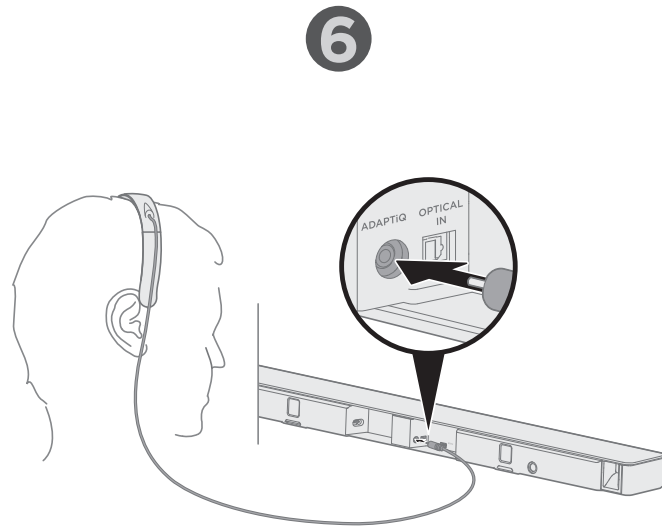



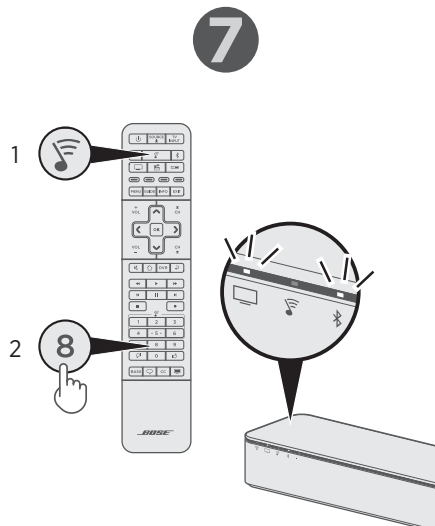

Konfigurowanie systemu w celu przeprowadzenia kalibracji dźwięku ADAPTiQ®

1. Załóż zestaw słuchawkowy ADAPTiQ®.
2. Podłącz zestaw słuchawkowy do listwy dźwiękowej.



Przeprowadzanie kalibracji dźwięku ADAPTiQ®

1. Na pilocie zdalnego sterowania listwą SoundTouch® 300 naciśnij przycisk .
2. Naciśnij przycisk **8** i przytrzymaj go do momentu, aż wskaźniki  i  na listwie dźwiękowej zaświecą się na zielono.

UWAGA: Do zmiany języka służą przyciski  i  na panelu nawigacyjnym.

Masz pytania?
global.Bose.com/Support/VI300

1

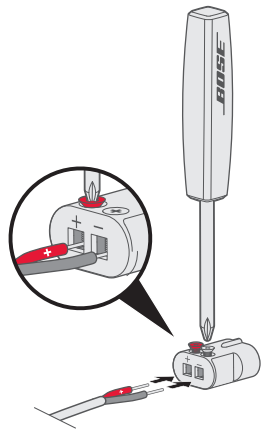

2

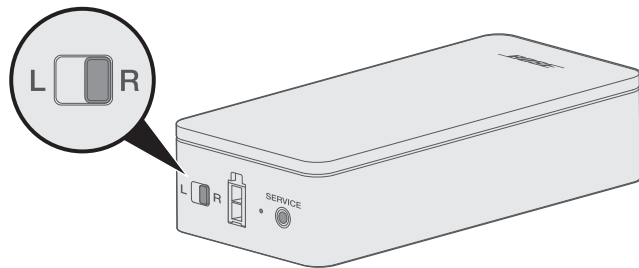

Conecte os adaptadores

1. Insira os fios dos cabos codificados por cores do alto-falante nos terminais correspondentes.
2. Gire os parafusos para a direita (sentido horário) para prender os fios nos terminais.
3. Repita as etapas 1 e 2 para conectar o outro adaptador.

Identifique as configurações dos comutadores nos receptores sem fio

1. Confirme que o comutador no outro receptor sem fio está configurado para **R** (lado direito).
2. Confirme que o comutador em um receptor sem fio está configurado para **L** (lado esquerdo).

3

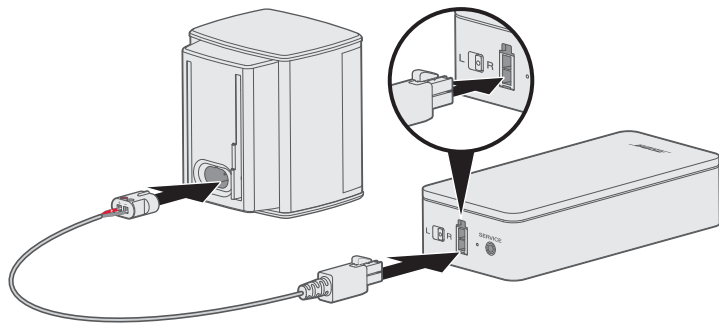

Conecte os alto-falantes traseiros

1. Insira o adaptador na parte traseira do alto-falante.
2. Insira o conector de dois pontos no receptor sem fio.
3. Repita as etapas 1 e 2 para configurar o outro alto-falante.

4

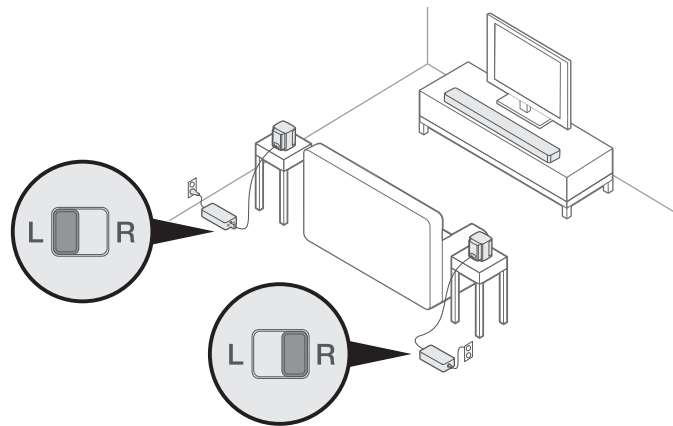

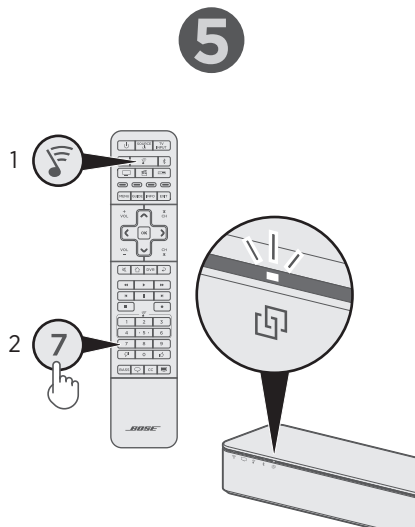

Posicione os alto-falantes traseiros e os receptores sem fio

1. De frente para a TV, coloque o alto-falante e o receptor sem fio **R** no lado **direito** do ambiente.
2. De frente para a TV, coloque o alto-falante e o receptor sem fio **L** no lado **esquerdo** do ambiente.
3. Conecte à energia.



Emparelhe com uma barra de som SoundTouch® 300

1. No controle remoto SoundTouch® 300, pressione .
2. Pressione **7** por alguns segundos até  piscar em branco.
O sistema emite um som quando é emparelhado.

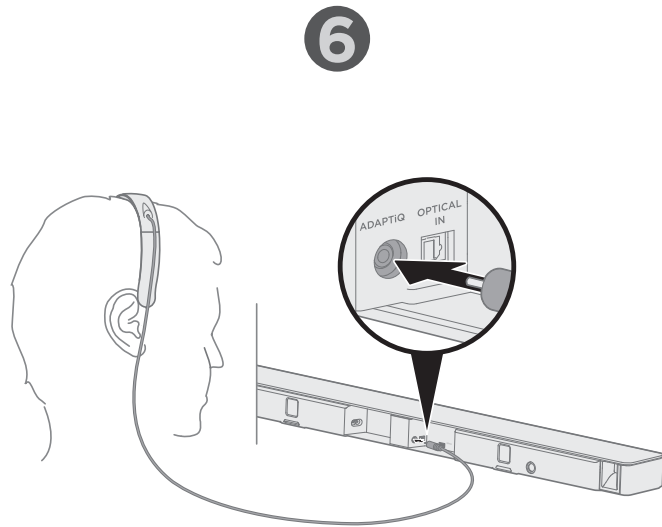



Configure o ADAPTiQ®

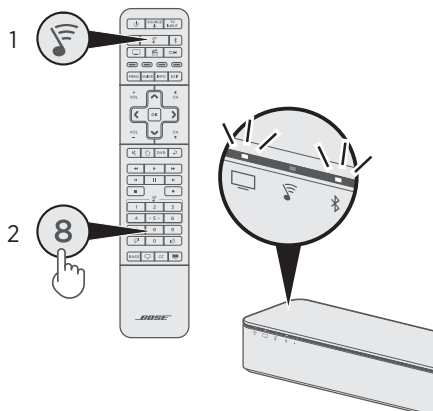

1. Coloque o fone de ouvido ADAPTiQ®.
2. Conecte o fone de ouvido à barra de som.

7



Execute o ADAPTiQ®

1. No controle remoto SoundTouch® 300, pressione .
2. Pressione **8** por alguns segundos, até  e  na barra de som acenderem em verde.

OBSERVAÇÃO: Para navegar entre os idiomas, pressione  e  no painel de navegação.

Alguma dúvida?
global.Bose.com/Support/VI300

1

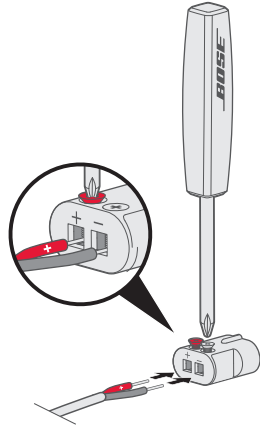

2

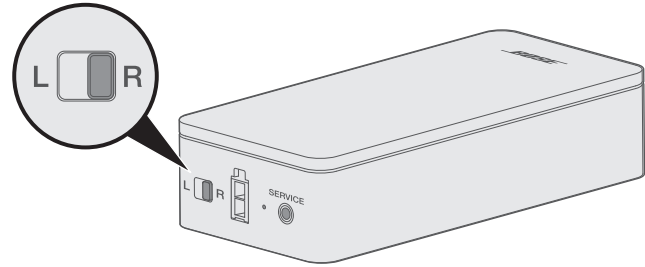

Anslut adaptrarna

1. För in de färgkodade högtalarledningarna i motsvarande kontakter.
2. Vrid skruvarna medurs för att fästa ledningarna i kontakterna.
3. Upprepa steg 1 och 2 för att ansluta den andra adaptern.

Identifiera inställningarna för omkopplaren på trådlösa mottagare

1. Kontrollera att omkopplaren på den andra trådlösa mottagaren är inställd på **R** (höger).
2. Kontrollera att omkopplaren på en trådlös mottagare är inställd på **L** (vänster).

3

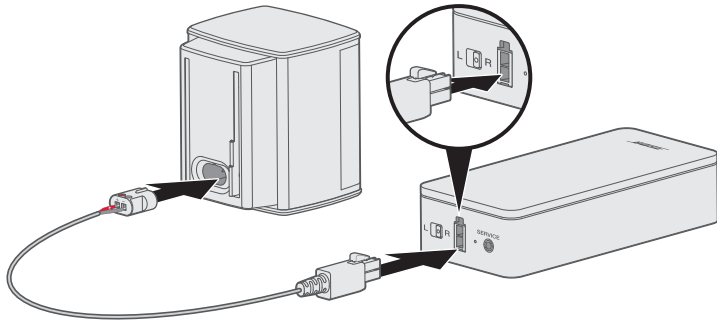

Anslut bakre högtalare

1. Sätt in adaptern på avsedd plats på baksidan av högtalaren.
2. Sätt in 2-stiftskontakten i den trådlösa mottagaren.
3. Upprepa steg 1 och 2 för att ställa in andra högtalare.

4

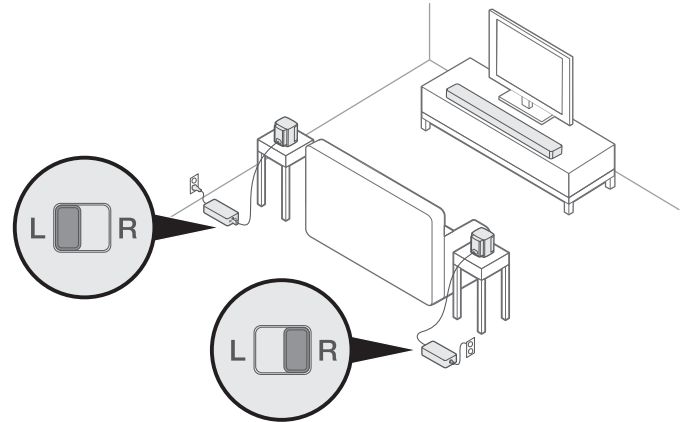



Placera ut bakre högtalare och trådlösa mottagare

1. Vänd dig mot TV:n och placera högtalaren och den trådlösa **R**-mottagaren på den **högra** sidan av rummet.
2. Vänd dig mot TV:n och placera högtalaren och den trådlösa **L**-mottagaren på den **vänstra** sidan av rummet.
3. Anslut till en kraftkälla.

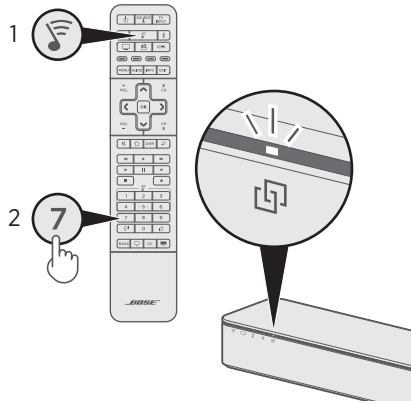
5



Synkronisera med en SoundTouch® 300-högtalarpanel

1. Tryck på  på SoundTouch® 300-fjärrkontrollen.
2. Tryck ned **7** tills  börjar blinka med vitt sken.
Du hör en ton från systemet när synkroniseringen är klar.

6

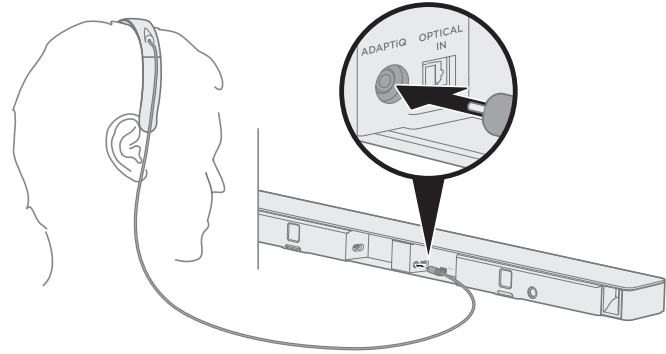



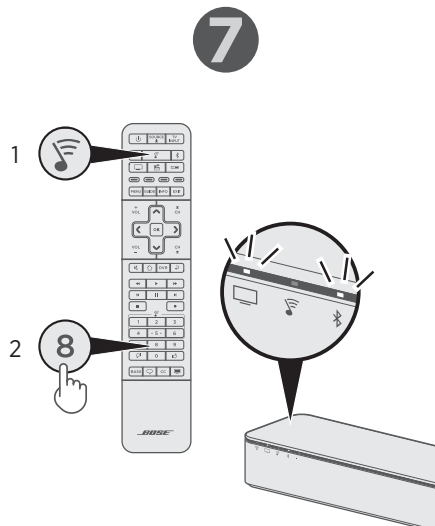

Göra ADAPTiQ®-inställning

1. Ta på dig ADAPTiQ®-headsetet.
2. Anslut headsetet till högtalarpanelen.



Använda ADAPTiQ®

1. Tryck på  på SoundTouch® 300-fjärrkontrollen.
 2. Tryck ned **8** tills  och  på högtalarpanelen lyser med grönt sken.
- OBS!** Tryck på  och  på navigeringsplattan för att välja rätt språk.

Har du några frågor?
global.Bose.com/Support/VI300

 global.Bose.com/Support/VI300



772155-0010

BOSE[®]
Better sound through research[®]

©2016 Bose Corporation, The Mountain,
Framingham, MA 01701-9168 USA
AM772155 Rev. 01