

BOSE[®]



Lifestyle[®] 135 series III home entertainment system

Setup Guide | คู่มือการติดตั้ง | 설치 안내서 | 安装指南 | 安裝指南 | دليل الإعداد

Important Safety Information

Please read this guide

Please take the time to follow the instructions in this owner's guide carefully. It will help you set up and operate your system properly and enjoy its advanced features. Please save this guide for future reference.

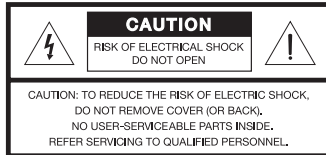

The lightning flash with arrowhead symbol within an equilateral triangle alerts the user to the presence of uninsulated, dangerous voltage within the system enclosure that may be of sufficient magnitude to constitute a risk of electric shock.



The exclamation point within an equilateral triangle, as marked on the system, is intended to alert the user to the presence of important operating and maintenance instructions in this owner's guide.



WARNING: Contains small parts which may be a choking hazard. Not suitable for children under age 3.



WARNINGS:

- To reduce the risk of fire or electrical shock, do not expose the product to rain or moisture.
- Do not expose this apparatus to dripping or splashing, and do not place objects filled with liquids, such as vases, on or near the apparatus. As with any electronic products, use care not to spill liquids into any part of the system. Liquids can cause a failure and/or a fire hazard.
- To prevent electric shock, match the wide blade of the line cord plug to the wide slot of the AC (mains) receptacle. Insert fully.
- Do not place any naked flame sources, such as lighted candles, on or near the apparatus.



CAUTIONS:

- Make no modifications to the system or accessories. Unauthorized alterations may compromise safety, regulatory compliance, and system performance.
- Long-term exposure to loud music may cause hearing damage. It is best to avoid extreme volume when using headphones, especially for extended periods.



Manufactured under license from Dolby Laboratories. Dolby and the double-D symbol are trademarks of Dolby Laboratories.



For DTS patents, see <http://patents.dts.com>. Manufactured under license from DTS Licensing Limited. DTS, the Symbol, & DTS and the Symbol together are registered trademarks, and DTS Digital Surround is a trademark of DTS, Inc. © DTS, Inc. All Rights Reserved.

The terms HDMI and the HDMI Logo are trademarks or registered trademarks of HDMI Licensing LLC in the United States and other countries.

This product is protected by certain intellectual property rights of Microsoft. Use or distribution of such technology outside of this product is prohibited without a license from Microsoft

Wi-Fi is a registered mark of the Wi-Fi Alliance.

©2014 Bose Corporation. No part of this work may be reproduced, modified, distributed, or otherwise used without written permission.

Important Safety Information

NOTES:

- The product label is located on the bottom or the back of the product.
- Where the mains plug or appliance coupler is used as the disconnect device, such disconnect device shall remain readily operable.
- The product must be used indoors. It is neither designed nor tested for use outdoors, in recreation vehicles, or on boats.
- This product is intended to be used only with the power supply provided.
- The speaker wire and interconnect cables included with the system are not approved for in-wall installation. Please check your local building codes for the correct type of wire and cable required for in-wall installation.
- Changes or modifications not expressly approved by Bose Corporation could void the user's authority to operate this equipment.
- Operate this product within the temperature range of 32°F to 104°F (0°C to 40°C).

Important Safety Instructions

1. Read these instructions.
2. Keep these instructions.
3. Heed all warnings.
4. Follow all instructions.
5. Do not use this apparatus near water.
6. Clean only with a dry cloth.
7. Do not block any ventilation openings. Install in accordance with the manufacturer's instructions.
8. Do not install near any heat sources such as radiators, heat registers, stoves, or other apparatus (including amplifiers) that produce heat.
9. Do not defeat the safety purpose of the polarized or grounding-type plug. A polarized plug has two blades with one wider than the other. A grounding type plug has two blades and a third grounding prong. The wide blade or the third prong are provided for your safety. If the provided plug does not fit into your outlet, consult an electrician for replacement of the obsolete outlet.
10. Protect the power cord from being walked on or pinched particularly at plugs, convenience receptacles, and the point where they exit from the apparatus.
11. Only use attachments/accessories specified by the manufacturer.
12.  Use only with the cart, stand, tripod, bracket, or table specified by the manufacturer, or sold with the apparatus. When a cart is used, use caution when moving the cart/apparatus combination to avoid injury from tip-over.
13. Unplug this apparatus during lightning storms or when unused for long periods of time.
14. Refer all servicing to qualified personnel. Servicing is required when the apparatus has been damaged in a way, such as power-supply cord or plug is damaged, liquid has been spilled or objects have fallen into the apparatus, the apparatus has been exposed to rain or moisture, does not operate normally, or has been dropped.



This symbol means the product must not be discarded as household waste, and should be delivered to an appropriate collection facility for recycling. Proper disposal and recycling helps protect natural resources, human health and the environment. For more information on disposal and recycling of this product, contact your local municipality, disposal service, or the shop where you bought this product.



Bose Corporation hereby declares that this product is in compliance with the essential requirements and other relevant provisions of Directive 1999/5/EC and all other applicable EU directive requirements. The complete declaration of conformity can be found at: www.Bose.com/compliance.

Important Safety Information

Names and Contents of Toxic or Hazardous Substances or Elements						
Part Name	Toxic or Hazardous Substances and Elements					
	Lead (Pb)	Mercury (Hg)	Cadmium (Cd)	Hexavalent (CR(VI))	Polybrominated Biphenyl (PBB)	Polybrominated diphenylether (PBDE)
PCBs	X	0	0	0	0	0
Metal parts	X	0	0	0	0	0
Plastic parts	0	0	0	0	0	0
Speakers	X	0	0	0	0	0
Cables	X	0	0	0	0	0
0: Indicates that this toxic or hazardous substance contained in all of the homogeneous materials for this part is below the limit requirement in SJ/T 11363-2006.						
X: Indicates that this toxic or hazardous substance contained in at least one of the homogeneous materials used for this part is above the limit requirement in SJ/T 11363-2006.						

Please complete and retain for your records.

The serial and model numbers can be found on the bottom panel of the product.

Lifestyle® model: _____

Control console serial number: _____

Acoustimass® serial number: _____

Speaker array serial number: _____

Purchase date: _____

Please keep your receipt together with this Setup Guide and the Operating Guide.

Introduction

About your Lifestyle® system	5
Introducing SoundTouch™ from Bose.....	5
About SoundTouch™ on your system.....	5

Unpacking the System

Carton contents.....	6
Accessories boxes	6
Cables and power cords box.....	6
Essentials box.....	7
Control console box	7

System Setup

Putting the system together	10
Wall mounting the soundbar	10
Set up the Soundbar	10
Set up the control console.....	12
Set up the Acoustimass® module.....	15
First time startup	17
Set up the remote control	17
Turn your system on.....	18
Install the SoundTouch™ app	19
Add the system to your existing SoundTouch™ account.....	19
If you have setup problems	20
Contacting customer service	20

Introduction

About your Lifestyle® system

Thank you for choosing a Bose® Lifestyle® system for your home. This elegant and easy-to-use system delivers superior performance for both music and video. This guide provides step-by-step instructions for setting up your new system. Refer to the Operating guide for system features.

Your new home entertainment system includes a soundbar, control console, Acoustimass® module, SoundTouch™ wireless adapter and a universal remote control.

Introducing SoundTouch™ from Bose

With SoundTouch™, you can stream Internet radio, music services (where available), and your music library. If you have Wi-Fi® at home, you're ready to enjoy your favorite music in any room you want.

Key Benefits

- Enjoy wireless access to Internet radio, music services and your music library.
- Stream your favorite music easily with personalized Presets.
- Works with your existing home Wi-Fi network.
- Free SoundTouch™ app for your computer, smartphone or tablet provides more powerful control.
- Simply add additional systems at any time for a multi-room listening experience.
- Wide selection of Bose® audio systems lets you choose the right solution for any room.

About SoundTouch™ on your system

The SoundTouch™ wireless adapter in the essentials box enables SoundTouch™ on your Lifestyle® system. Setting up your wireless adapter is part of the UNIFY® setup process. Do not connect your wireless adapter until prompted by UNIFY®. See page 18.

System Features

- Enables your Bose® home entertainment system to stream music wirelessly using SoundTouch™.
- SoundTouch™ source lets you view and control your Presets, Recents, and Now Playing content on your TV.
- The SoundTouch™ app lets you explore Internet radio, music services (where available), and your music library from your computer, smartphone or tablet.
- Personalize up to six Presets to deliver your music with just one touch from your remote control.

For information on using SoundTouch™, download the SoundTouch™ user's guide for your Lifestyle® system from the Bose website.

Unpacking the System

Carefully unpack the carton and confirm that the following parts are included.

Note: If part of the system is damaged, do not use it. Contact your authorized Bose® dealer or Bose customer service. Refer to the contact sheet in the carton.

Carton Contents

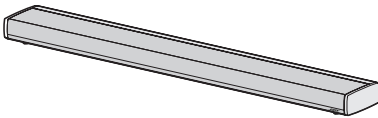

Soundbar

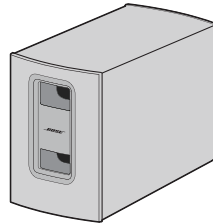

Acoustimass® module

Accessories boxes

Each box is identified by an icon on the box. These icons appear in the system setup steps to indicate where parts are located.

Cables and power cords box

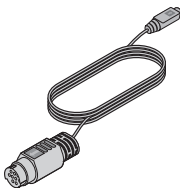
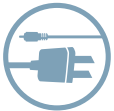

Audio input cable

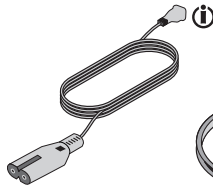

AC power cord



AM antenna

i The appropriate power cords for your region are supplied.

Unpacking the System

Essentials box

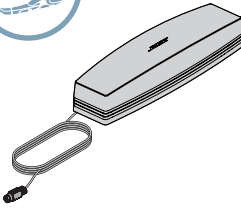

SoundTouch™ wireless adapter



ADAPTiQ® audio calibration headset



Operating guide



FM antenna

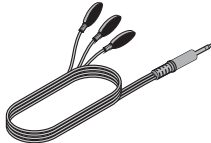

IR emitter cable

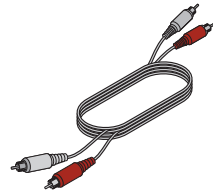

Stereo audio cable

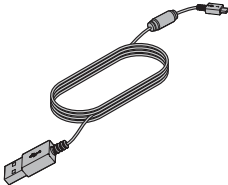

USB cable



USB drive (for system updating only)



Acoustimass module feet and Soundbar extension feet

Control console box

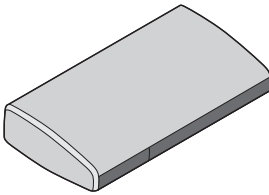

Control console

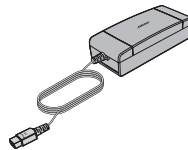

Power supply

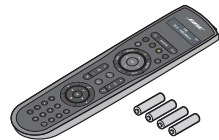

Remote control and Batteries

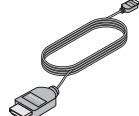

HDMI™ cable

Putting the system together

Notes:

- The Lifestyle® 135 series III home entertainment system uses the reflective surfaces of your room to deliver wide, spacious sound. For best sound quality, the soundbar should not be placed inside a cabinet, or diagonally in a corner.
- Keep other wireless equipment, such as wireless computer network routers, cordless phones, microwave ovens, or other WI-FI® enabled audio/video devices away from the soundbar and Acoustimass® module.

Wall mounting the soundbar

The soundbar can be mounted on a wall. To do this, contact Bose® to purchase the WB-135 Wall Mount Kit.

CAUTIONS:

- Do not use any wall-mounting hardware other than the WB-135 Wall Mount Kit to mount the soundbar on a wall.
- Do not place the soundbar near or over a source of heat, such as a fireplace. Any damage that may occur to your soundbar as a result of placing it over a fireplace will not be covered by the limited warranty on your Lifestyle® system.

Set up the soundbar

What you need:

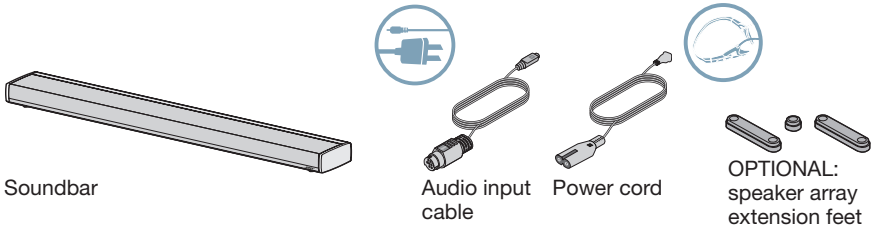

- A.** Lay the soundbar grille-side down on the table in front of your TV.

Notes:

- To protect the surface of your table you may want to put a protective cloth under the soundbar until setup is complete. The foam bag removed from the soundbar could be used for this purpose.
- Remove all protective films. These may affect acoustic performance if left in place.

System Setup

- B.** Insert the audio input cable into the **Audio In** connector on the soundbar. Make sure the flat surface with the arrow on the plug faces up.

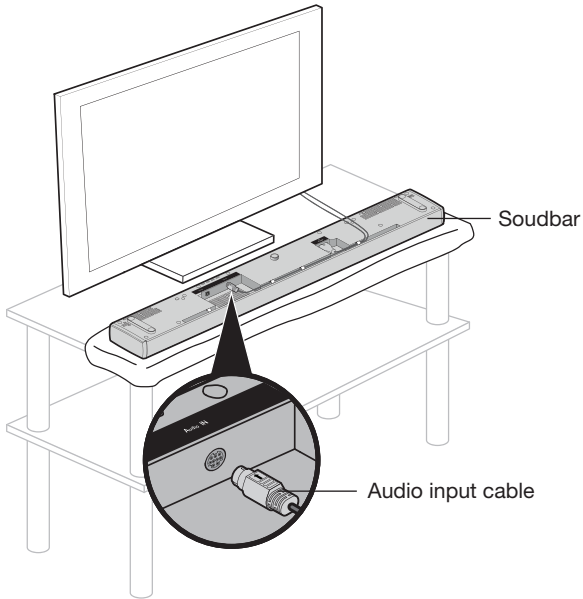

- C.** Insert the small end of the power cord into the **Power** connector.
- Note:** Do not plug the power cord into an AC power outlet until instructed to do so.

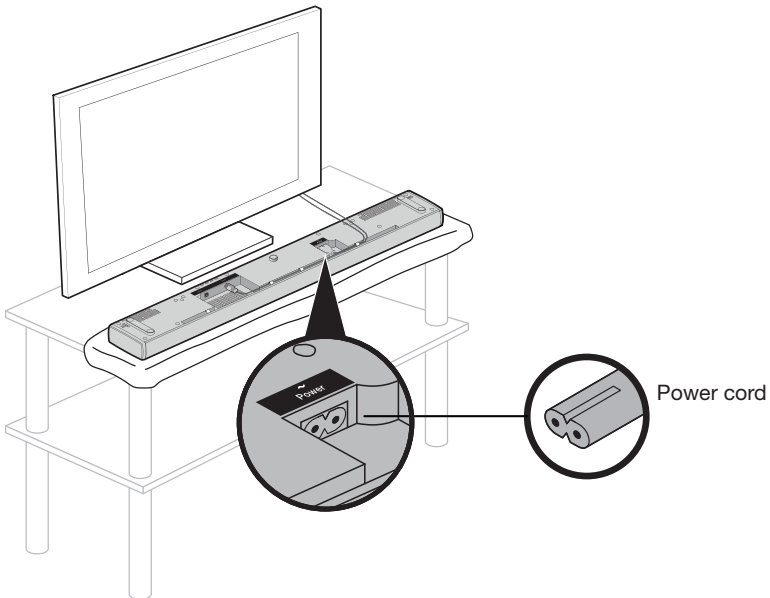

D. Arrange the cables as needed for your setup location.

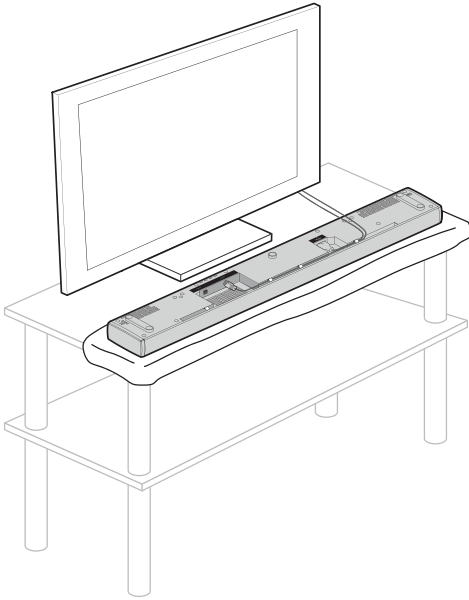

OPTIONAL: Secure cables under the clips in the channel running along the length of the soundbar.

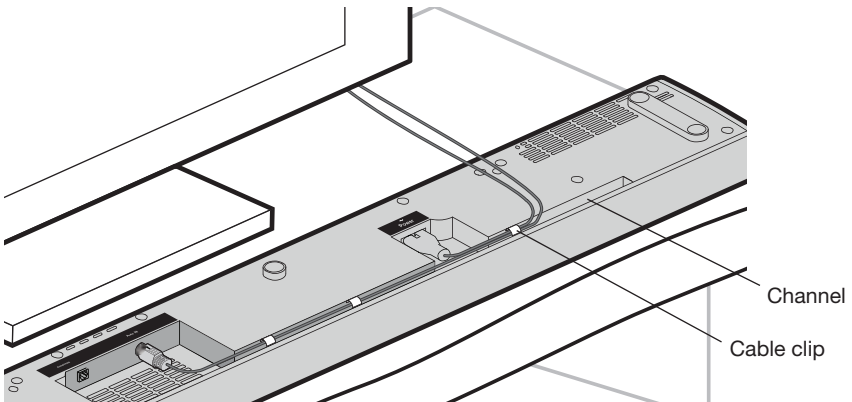

E. Turn the soundbar over and place it in front of your TV with the speaker grille facing into the room.

System Setup

CAUTIONS:

- The soundbar must be placed on a solid flat surface. For proper support, all of the feet on the bottom of the soundbar must be resting on the table top.
- When positioning the soundbar, make sure it is not blocking any ventilation openings on your TV. Refer to your TV's owner's guide and install in accordance with the manufacturer's instructions.

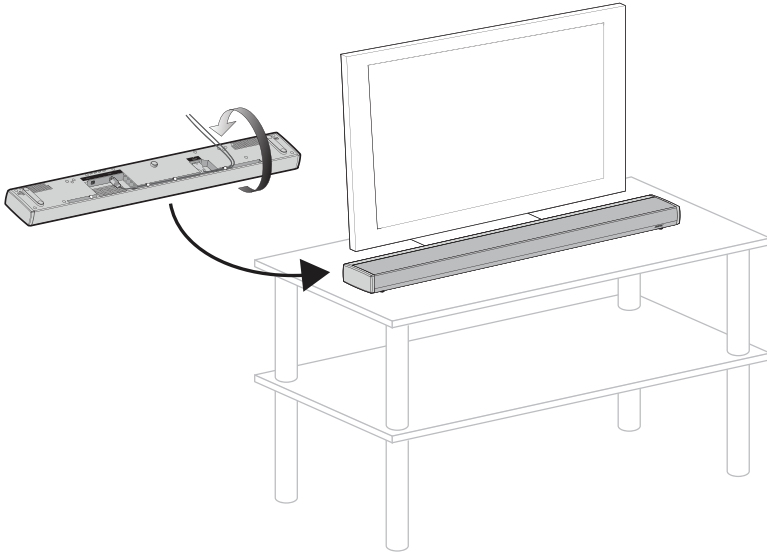

OPTIONAL: To raise the soundbar and allow more space under it, you can install the optional extension feet (supplied).

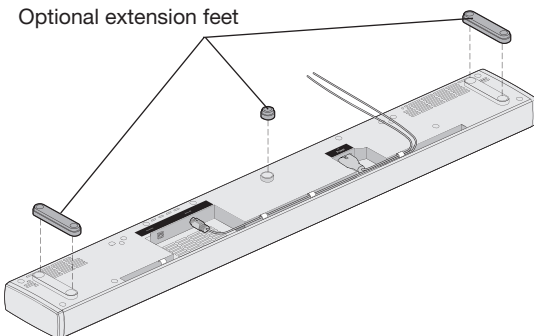

Set up the control console

What you need:

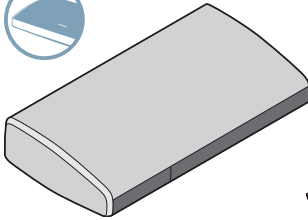

Control console

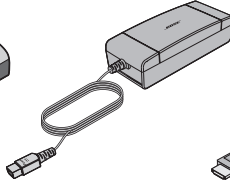

Power supply

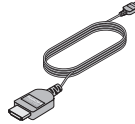

High-speed
HDMI™ cable



Power cord

- A.** Place the control console on a flat, stable surface near your TV.

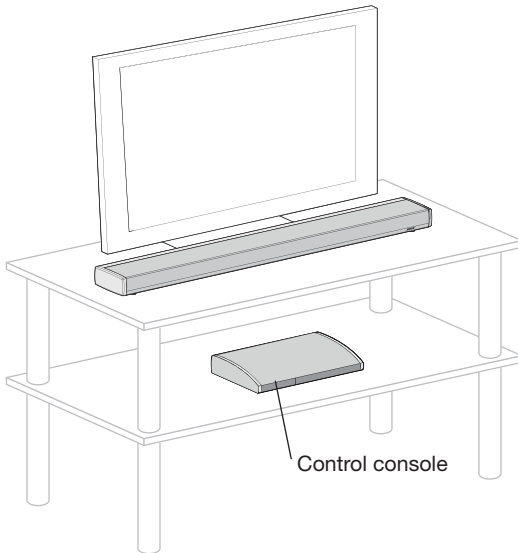

Note: Until your system is completely installed, it may be helpful to keep the control console positioned for easy access to its rear connector panel.

System Setup

- B. Insert one end of the High-speed HDMI™ cable into an HDMI INPUT connector on your TV.

If an HDMI cable is already connected to an HDMI input on your TV, you can use this cable. Just disconnect the other end.

Note: If you plan on viewing 3D content, make sure you use the supplied high-speed HDMI cable.

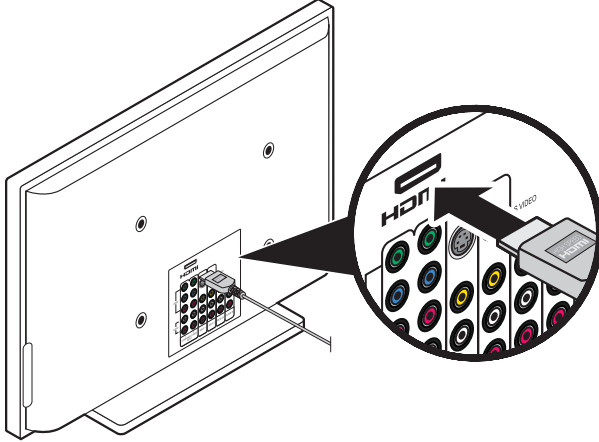

- C. Insert the other end of the HDMI cable into the **HDMI OUT Video to TV** connector on the control console.

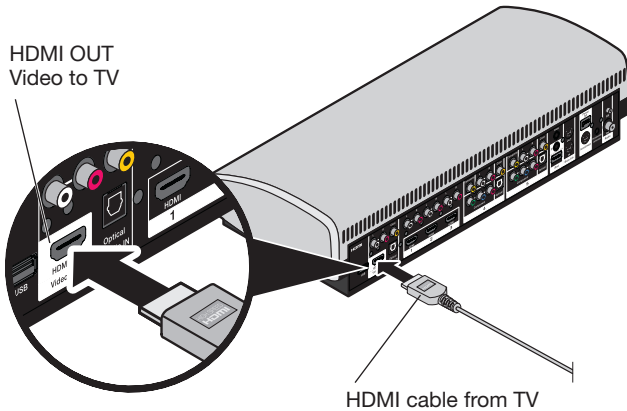

System Setup

- D. Insert the soundbar's audio input cable into the **Audio OUT** connector on the control console.

Make sure the flat surface with the arrow on the plug faces up.

Note: Make sure the audio input cable is not connected to a Bose link connector.

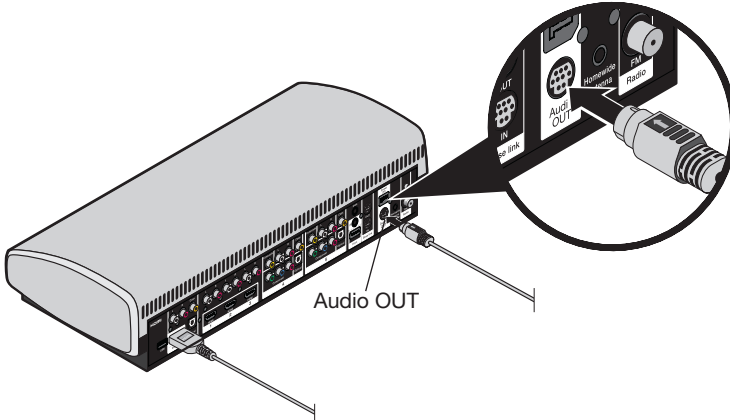

- E. Insert the power supply output cord into the **Power** connector.

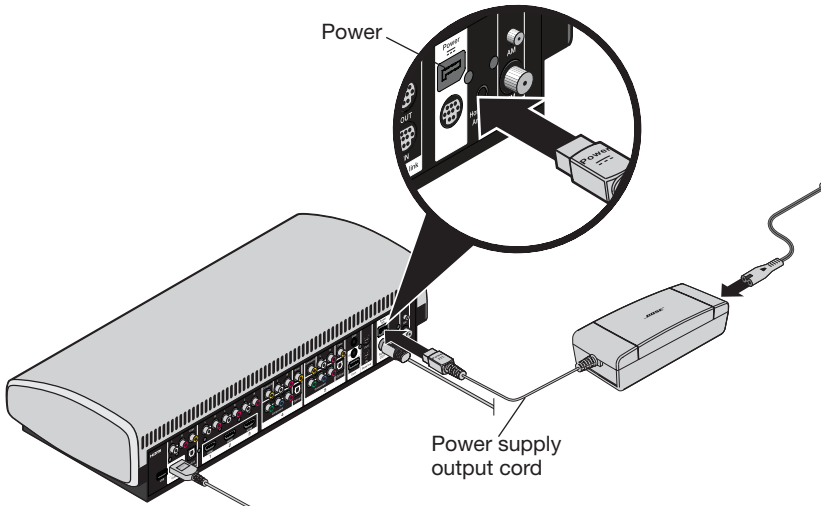

- F. Insert a power cord into the power supply.

- G. Plug the power cords from the soundbar and the control console into an AC (mains) power outlet.

System Setup

Set up the Acoustimass® module

What you need:

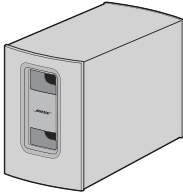

Acoustimass module



Rubber feet



Power cord

CAUTION: Choose a stable and level surface for the Acoustimass module. Vibration can cause the speaker to move, particularly on smooth surfaces like marble, glass, or highly polished wood.

- A. When placing the Acoustimass module on bare floors, or other smooth surfaces, attach the included rubber feet to the bottom of the module for greater stability and to protect your floor.

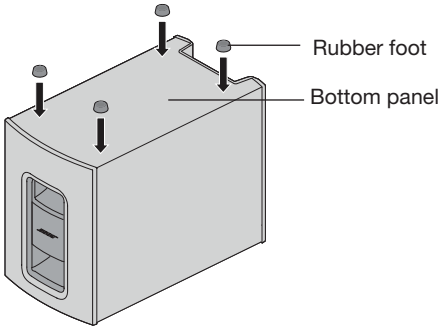

- B. Insert the small end of the power cord into the **Power** connector.

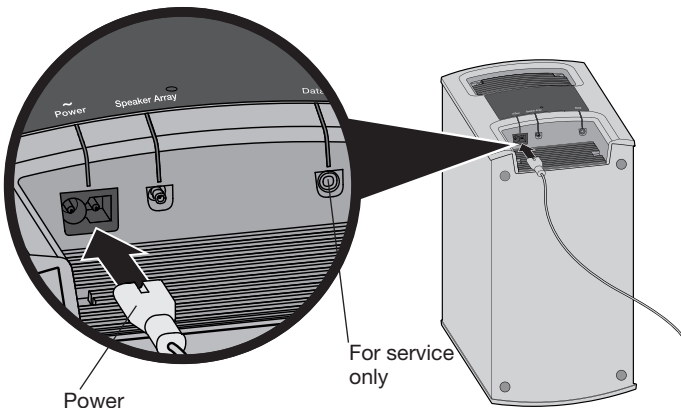

System Setup

- C. Place the Acoustimass® module according to the following guidelines:
- For best sound quality, stand the Acoustimass module on its feet along the same wall as your TV, or along any other wall in the front third of the room.
 - The front opening of the module can face any direction.
 - Make sure there is an AC (mains) power outlet nearby.

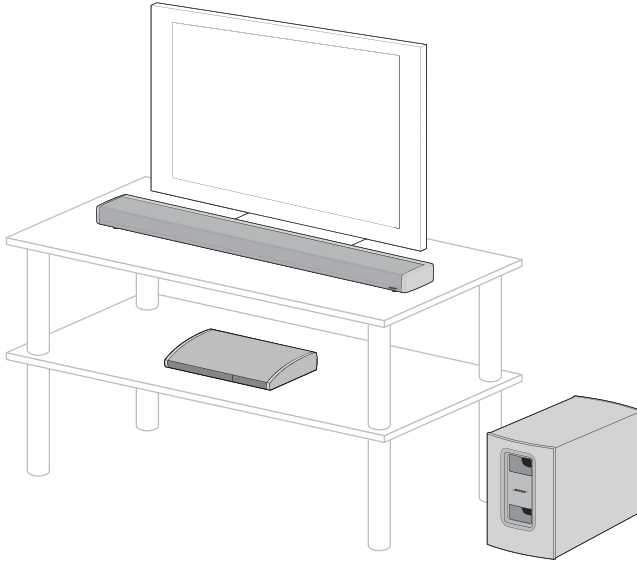

CAUTION: Do not operate the Acoustimass module on its front end, back end, side, or top.

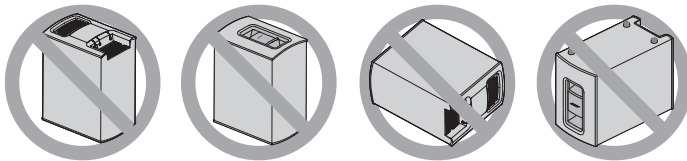

Note: Remove all protective films. These may affect acoustic performance if left in place.

- D. Plug the Acoustimass module's power cord into an AC (mains) power outlet.

System Setup

First time startup

What you need:

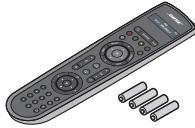

Remote control and batteries



ADAPTiQ® audio calibration headset

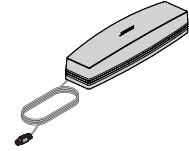

SoundTouch™ wireless adapter

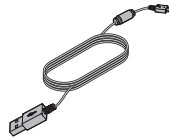

USB cable

Before you start:

- Do not connect any devices to the control console until instructed by UNIFY®.
- Make sure the soundbar and Acoustimass® module are in their final positions.

Set up the remote control

- A. Slide the battery compartment cover off the back of the remote control.

AA (IEC LR6) batteries (4)

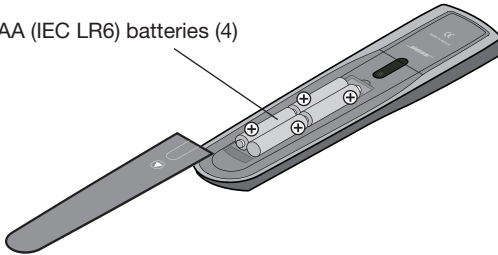

- B. Install the four AA (IEC LR6) batteries, matching the polarity markings (+ and -) to the markings inside the battery compartment.
- C. Slide the battery cover back into place.

Power on your system

- A.** Press the power button on the control console.

Because the system is in a low power state when in standby, it takes several seconds to start. When the status indicator on the control console changes from blinking to steady green, your system is ready to use.

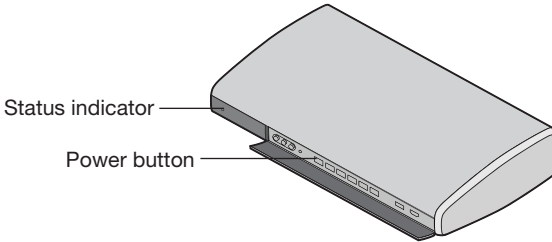

- B.** Check that the status indicator on the soundbar is off.

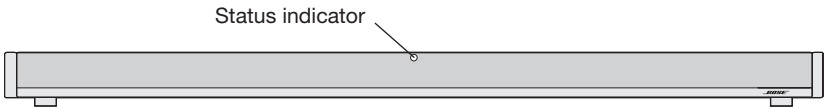

If the status indicator is blinking orange:

- There is no wireless connection between the speaker and the Acoustimass® module. Refer to “Troubleshooting” in the operating guide.

- C.** Power on your TV.
- D.** Using your TV’s remote control, change the TV input to the one that is connected to your Lifestyle® 135 series III home entertainment system.
- E.** Follow the instructions on your TV screen. The system instructs you to do the following:
- Select your language.
 - Run the ADAPTiQ® audio calibration system.
 - Connect and set up audio/video devices using the UNIFY® intelligent integration system.
 - Configure your Bose® remote to control your connected devices.
 - Complete network setup with the SoundTouch™ wireless adapter.

System Setup

Install the SoundTouch™ app

Once you have completed network setup with your SoundTouch™ wireless adapter, create a SoundTouch™ account.

IMPORTANT: If you already have SoundTouch™ set up for another system, you don't need to reinstall the app. See "Add the system to your existing SoundTouch™ account."

1. On your computer, open a browser and go to **http://www.Bose.com/soundtouch_app**

Tip: Use the computer where your music library is stored.

http://www.Bose.com/soundtouch_app



2. Download and install the SoundTouch™ app.
3. Launch the app by double-clicking the SoundTouch™ icon.
4. Click **CONTINUE**.
The SoundTouch™ system setup screen appears.
5. Select **IT IS ALREADY CONNECTED**.
6. Follow the instructions on your computer to complete setup, including creating a SoundTouch™ account, locating your music library, signing in to music services, exploring music, and personalizing your Presets.

Add the system to your existing SoundTouch™ account

Complete these steps only if you already have other SoundTouch™ systems.

1. Launch the app.
2. Click **EXPLORE > SETTINGS > Systems > ADD SYSTEM**.
The SoundTouch™ system setup screen appears.
3. Select **IT IS ALREADY CONNECTED**.

If you have setup problems

If you experience any difficulties during the setup process, such as an unrecognized device remote or a connection error, you can go to the UNIFY® menu at any time and correct or change part of your system setup. See “Changing Your System Setup” in your system operating guide.

For help in trying to resolve any problems, refer to “Troubleshooting” in your system operating guide.

Contacting customer service

For additional help in solving problems, contact Bose® Customer Service. Refer to the contact sheet in the carton.



720994-0010

BOSE[®]
Better sound through research[®]

©2014 Bose Corporation, The Mountain,
Framingham, MA 01701-9168 USA
AM720994 Rev. 00