

BOSE[®]



Wave[®] SoundTouch[™] 
music system

Owner's Guide | คู่มือผู้ใช้ | 사용자 안내서 | 用户指南 | 使用者指南 | دليل المالك

Important Safety Information

Please read this owner's guide

Please take the time to follow the instructions in this owner's guide carefully. It will help you set up and operate your system properly and enjoy its advanced features. Please save this owner's guide for future reference.

WARNINGS:

- To reduce the risk of fire or electrical shock, do not expose the product to rain or moisture.
- Do not expose this apparatus to dripping or splashing, and do not place objects filled with liquids, such as vases, on or near the apparatus. As with any electronic products, use care not to spill liquids into any part of the system. Liquids can cause a failure and/or a fire hazard.
- Keep battery away from children. May cause a fire or chemical burn if mishandled. Do not recharge, disassemble, heat above 212°F (100°C), or incinerate. Dispose of used batteries promptly. Replace only with a battery of the correct type and model number.
- Do not ingest battery, chemical burn hazard. The remote control supplied with this product contains a coin/button cell battery. If the coin/button cell battery is swallowed it can cause severe internal burns in just 2 hours and can lead to death. Keep new and used batteries away from children. If the battery compartment does not close securely, stop using the product and keep it away from children. If you think the battery may have been swallowed or placed inside any part of the body seek immediate medical attention.
- Danger of explosion if battery is incorrectly replaced. Replace only with an agency approved (ex. UL) CR2032 or DL2032 3-volt lithium battery.
- Do not place any naked flame sources, such as lighted candles, on or near the apparatus.
- The Wave® SoundTouch™ music system (the system and SoundTouch™ pedestal combination, or the SoundTouch™ pedestal itself) is not to be used with the under-cabinet/wall bracket available from Bose.



This product contains magnetic material. Please contact your physician if you have any questions on whether this might affect the operation of your implantable medical device.



Contains small parts which may be a choking hazard. Not suitable for children under age 3.



The lightning flash with arrowhead symbol within an equilateral triangle alerts the user to the presence of uninsulated dangerous voltage within the system enclosure that may be of sufficient magnitude to constitute a risk of electrical shock.



The exclamation point within an equilateral triangle, as marked on the system, is intended to alert the user to the presence of important operating and maintenance instructions in this owner's guide.

CAUTIONS:

- To prevent electric shock, match the wide blade of the line cord plug to the wide slot of the AC (mains) receptacle. Insert fully.
- Make no modifications to the system or accessories. Unauthorized alterations may compromise safety, regulatory compliance, and system performance.
- Long-term exposure to loud music may cause hearing damage. It is best to avoid extreme volume when using headphones, especially for extended periods.
- Use of controls or adjustments or performance of procedures other than those specified herein may result in hazardous radiation exposure from the internal laser component. The compact disc player should not be adjusted or repaired by anyone except properly qualified service personnel.

Notes:

- The product label is located on the bottom of the product.
- The product must be used indoors. It is neither designed nor tested for use outdoors, in recreational vehicles, or on boats.
- Where the mains plug or appliance coupler is used as the disconnect device, such disconnect device shall remain readily operable.



Please dispose of used batteries properly, following any local regulations. Do not incinerate.



This symbol means the product must not be discarded as household waste, and should be delivered to an appropriate collection facility for recycling. Proper disposal and recycling helps protect natural resources, human health and the environment. For more information on disposal and recycling of this product, contact your local municipality, disposal service, or the shop where you bought this product.

The temperature range of this product is 32°F (0°C) to 113°F (45°C).

Class 1 laser product

This CD player is classified as a CLASS 1 LASER PRODUCT according to EN/IEC 60825. The CLASS 1 LASER PRODUCT label is located on the bottom of the unit.

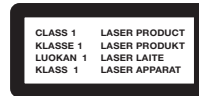

1. Read these instructions.
2. Keep these instructions.
3. Heed all warnings.
4. Follow all instructions.
5. Do not use this apparatus near water.
6. Clean only with a dry cloth.
7. Do not block any ventilation openings. Install in accordance with the manufacturer's instructions.
8. Do not install near any heat sources, such as radiators, heat registers, stoves or other apparatus (including amplifiers) that produce heat.
9. Protect the power cord from being walked on or pinched, particularly at plugs, convenience receptacles, and the point where they exit from the apparatus.
10. Only use attachments/accessories specified by the manufacturer.
11. Unplug this apparatus during lightning storms or when unused for long periods of time.
12. Refer all servicing to qualified service personnel. Servicing is required when the apparatus has been damaged in any way: such as power supply cord or plug is damaged; liquid has been spilled or objects have fallen into the apparatus; the apparatus has been exposed to rain or moisture, does not operate normally, or has been dropped.

NOTE: This equipment has been tested and found to comply with the limits for a Class B digital device, pursuant to Part 15 of the FCC rules. These limits are designed to provide reasonable protection against harmful interference in a residential installation. This equipment generates, uses, and can radiate radio frequency energy and, if not installed and used in accordance with the instructions, may cause harmful interference to radio communications. However, this is no guarantee that interference will not occur in a particular installation. If this equipment does cause harmful interference to radio or television reception, which can be determined by turning the equipment off and on, you are encouraged to try to correct the interference by one or more of the following measures:

- Reorient or relocate the receiving antenna.
- Increase the separation between the equipment and receiver.
- Connect the equipment to an outlet on a different circuit than the one to which the receiver is connected.
- Consult the dealer or an experienced radio/TV technician for help.

Changes or modifications not expressly approved by Bose Corporation could void the user's authority to operate this equipment.

This device complies with part 15 of the FCC Rules. Operation is subject to the following two conditions: (1) This device may not cause harmful interference, and (2) this device must accept any interference received, including interference that may cause undesired operation.

For the SoundTouch™ pedestal: This equipment should be installed and operated with a minimum distance of 8 in. (20 cm) between this device and your body.

CAN ICES-3(B)/NMB-3(B)

This Class B digital apparatus complies with Canadian ICES-003.

This device complies with FCC and Industry Canada RF radiation exposure limits set forth for general population. It must not be co-located or be operating in conjunction with any other antennas or transmitters.

This device complies with Industry Canada licence-exempt RSS standard(s). Operation is subject to the following two conditions:

(1) This device may not cause interference, and (2) this device must accept any interference, including interference that may cause undesired operation of the device.

Product data logger

This system features a product data logger that is designed to help Bose better understand product usage and performance over time. The product data logger records certain technical data and usage history, including but not limited to volume levels, on/off data, user settings, source inputs, power output, and setup data. We may use this data to provide you with better service and support on your system and to improve product design in the future. Special equipment is required to read the data stored by the product data logger and such data can only be retrieved by Bose if your system is returned to Bose for service or as returned merchandise. The product data logger does not collect any personally identifiable information about you and does not record title, genre or other information about the media content you access while using your system.

Important Safety Information

Names and Contents of Toxic or Hazardous Substances or Elements						
Toxic or Hazardous Substances and Elements						
Part Name	Lead (Pb)	Mercury (Hg)	Cadmium (Cd)	Hexavalent (CR(VI))	Polybrominated Biphenyl (PBB)	Polybrominated diphenylether (PBDE)
PCBs	X	0	0	0	0	0
Metal parts	X	0	0	0	0	0
Plastic parts	0	0	0	0	0	0
Speakers	X	0	0	0	0	0
Cables	X	0	0	0	0	0

0: Indicates that this toxic or hazardous substance contained in all of the homogeneous materials for this part is below the limit requirement in SJ/T 11363-2006.

X: Indicates that this toxic or hazardous substance contained in at least one of the homogeneous materials used for this part is above the limit requirement in SJ/T 11363-2006.

Please complete and retain for your records

Record the serial number of your new Wave® SoundTouch™ music system in the space below. The serial and model numbers can be found on the bottom panel.

Serial number: _____

Model number: _____

Purchase date: _____

We suggest you keep your receipt with this owner's guide.

"Made for iPod," "Made for iPhone," and "Made for iPad" mean that an electronic accessory has been designed to connect specifically to iPod, iPhone, or iPad, respectively, and has been certified by the developer to meet Apple performance standards. Apple is not responsible for the operation of this device or its compliance with safety and regulatory standards. Please note that the use of this accessory with iPod, iPhone, or iPad may affect wireless performance.

AirPlay, iPad, iPhone, iPod, and iTunes are trademarks of Apple Inc., registered in the U.S. and other countries. The trademark "iPhone" is used with a license from iPhone K.K.

App Store is a service mark of Apple Inc.

Android and Google Play are trademarks of Google Inc.

MPEG Layer-3 audio coding technology licensed from Fraunhofer IIS and Thompson.

SoundTouch and the wireless note design are trademarks of Bose Corporation in the U.S. and other countries.

Wi-Fi is a registered mark of the Wi-Fi Alliance.

Windows is a registered trademark of Microsoft Corporation in the United States and other countries.

The distinctive design of the Wave music system is a registered trademark of Bose Corporation in the U.S. and other countries.

© 2014 Bose Corporation. No part of this work may be reproduced, modified, distributed or otherwise used without prior written permission.

Presenting SoundTouch™ from Bose®	
Key benefits.....	6
About your Wave® SoundTouch™ music system	6
System features.....	6
The demonstration CD.....	6
The benefits of research.....	6
Setting Up the System	
Unpacking the system.....	7
Selecting a location.....	7
Connecting the system to the pedestal.....	7
Connecting the system to power	8
Adding the system to your Wi-Fi® network.....	8
Download and install the SoundTouch™ app	8
Connect the system to your Wi-Fi network	8
Setting the clock.....	8
Using the System	
Remote control	9
Touch pad.....	10
Reading the display.....	10
Turning the system on or off.....	10
Standby mode.....	10
Controlling the volume	10
Setting the Sleep timer	10
Controlling the System using the App	
Using the SoundTouch™ app	11
Getting help.....	11
Controlling the system from another smartphone, tablet, or computer	11
Personalizing your Presets	
How Presets work.....	12
What you need to know.....	12
Playing a Preset	12
Setting a Preset	12
Listening to Other Sources	
Playing an AirPlay stream from an AirPlay compatible device.....	13
Listening to FM or AM radio.....	13
Tuning to an FM/AM station	13
Storing FM/AM radio station Presets	13
TALK RADIO mode.....	13
Improving FM reception.....	13
Playing audio CDs.....	14
Playing MP3 CDs.....	14
CD Play Modes.....	15
Setting and Using the Alarms	
Alarm buttons and indicators	15
Using the Alarm buttons	15
Alarm status indicators.....	15
Setting the alarms	15
Using the alarms.....	16
Turning an alarm on or off	16
Snoozing an alarm	16
Connecting Other Equipment	
System connections	17
Using the AUX IN connector	18
Using headphones	18
Using an external antenna	19
Personalizing Your Wave® SoundTouch™ Music System	
The setup menu.....	20
Advanced Features	
Disabling Wi-Fi® capability.....	21
Re-enabling Wi-Fi® capability.....	21
Restarting the SoundTouch™ pedestal	21
Resetting the SoundTouch™ pedestal.....	21
Care and Maintenance	
Troubleshooting	22
Replacing the remote control battery	23
Cleaning.....	23
Customer service.....	23
Limited warranty	23
Technical information.....	23
Appendix: Setting up Using a Computer	
Important setup information.....	24
Using a desktop computer for setup	24
Setting up the system using a computer	24

Presenting SoundTouch™ from Bose®

With SoundTouch™, you can stream Internet radio, music services, and your music library. If you have Wi-Fi® at home, you're ready to enjoy your favorite music in any room you want.

Key benefits

- Enjoy wireless access to Internet radio, music services and your music library.
- Wireless setup using your smartphone or tablet.
- Stream your favorite music easily with personalized Presets.
- Works with your existing home Wi-Fi network.
- Free SoundTouch™ app for your computer, smartphone, or tablet provides more powerful control.
- Simply add additional systems at any time for a multi-room listening experience.
- Wide selection of Bose® audio systems lets you choose the right solution for any room.

About your Wave® SoundTouch™ music system

Your Wave® SoundTouch™ music system provides an elegant way to bring high quality sound wirelessly into any room. With the addition of the SoundTouch™ pedestal to the Wave® music system, you can listen to Wi-Fi music at the touch of a button.

Use the free SoundTouch™ app to set up and control SoundTouch™ on your system. "Adding the system to your Wi-Fi® network" on page 8.

System features

- Lifelike, room-filling sound from a compact system that can play all of your music.
- Enjoy your music at the touch of a button: SoundTouch™, including Internet radio, your music library, and music services; FM/AM radio; and CDs.
- Stream your music via AirPlay from your select iPhone, iPad, iPod devices.
- AUX connector enables playback from an external media player.
- Ethernet connector enables wired access to your home network.
- Free SoundTouch™ app for system setup and control.

The demonstration CD

We encourage you to listen to the demonstration music CD included in the carton. Simply insert the demonstration disc and your Wave® SoundTouch™ music system plays the CD automatically.

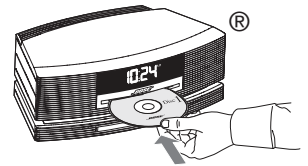

The benefits of research

Over fourteen years of research by Bose Corporation brings you the benefits of award-winning proprietary acoustic waveguide speaker technology. Using this technology, a tube efficiently transfers energy from a small speaker to the outside air over a wide range of low frequencies. And, long waveguides, folded into intricate patterns, fit into products small enough to be placed comfortably in your home. Your Wave® SoundTouch™ music system features dual tapered waveguide speaker technology, connecting two speakers to two 26" tapered waveguides which combine to produce unprecedented instrument timbre from a system this size.

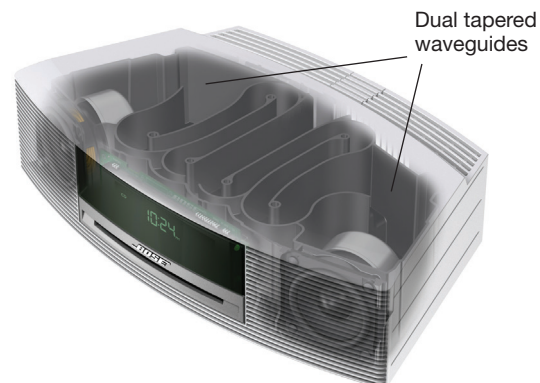

Unpacking the system

Carefully unpack the carton and confirm that the following parts are included.

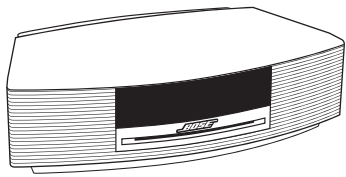

Wave® music system

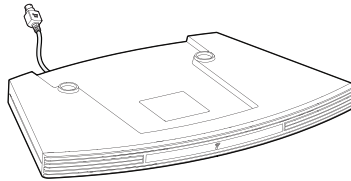

SoundTouch™ pedestal



Remote control
(battery installed)



Demonstration CD



USB cable
(setup only)



AC power cord(s)
(The appropriate cord for
your region is provided)

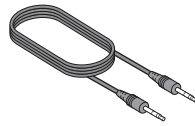

3.5 mm stereo
input cable

Note: If part of the system is damaged, do not use it. Contact your authorized Bose® dealer or Bose customer service. Refer to the quick start guide in the carton for contact information.

Save the carton and packing materials for transporting or storing the system.

Selecting a location

- To enjoy maximum audio performance:
 - Place your Wave® SoundTouch™ music system across the room from where you will be listening.
 - Place the system within two feet of a wall, and avoid placing directly in a corner.
- Place the system on a flat, stable surface.

CAUTIONS:

- Do not place your Wave® SoundTouch™ music system on a metal surface. It could interfere with AM reception.
- Do not place your Wave® SoundTouch™ music system on a heat-sensitive surface. Like all electrical equipment, it generates some heat.
- Do not use your Wave® SoundTouch™ music system in a damp location or any other place where moisture can get inside.

Connecting the system to the pedestal

The SoundTouch™ pedestal provides the network connection for the Wave® music system.

1. Place the SoundTouch™ pedestal on a flat, stable surface.
2. Carefully set your Wave® music system on top of the SoundTouch™ pedestal.
 - Place the rear feet of the Wave® music system into the recesses on top of the SoundTouch™ pedestal.
 - Make sure the Wave® music system sits flat and the side edges of both units are aligned.

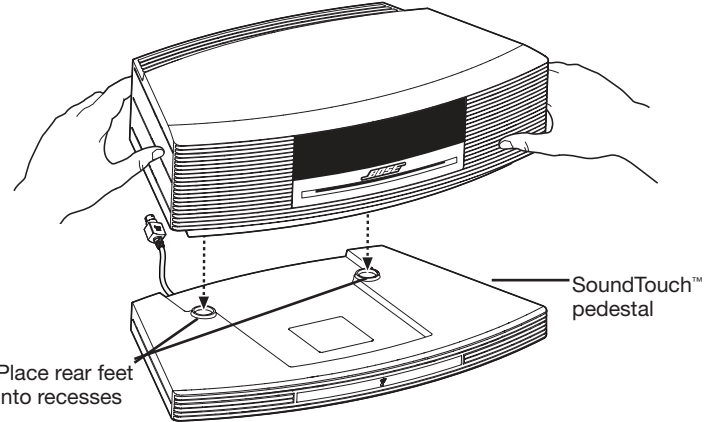

3. Insert the SoundTouch™ pedestal's cable into the **Bose link** connector.

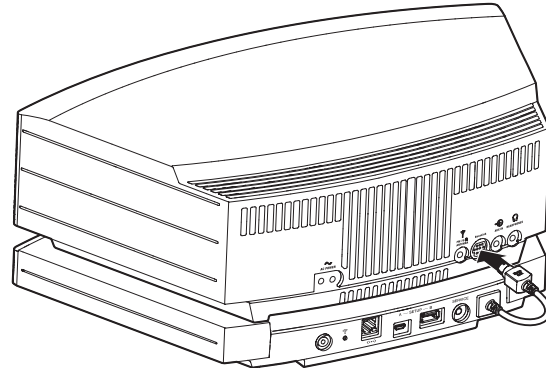

Setting up the System

Connecting the system to power

1. Insert the small end of the AC power cord into the **AC Power** connector.
2. Plug the power cord into an AC (mains) power outlet.

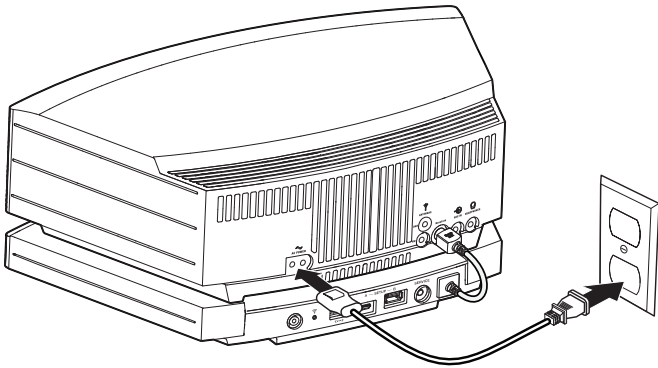

Adding the system to your Wi-Fi® network

To add the system to your network, you must download and install the SoundTouch™ app onto a smartphone or tablet that is connected to your network. Use the app to connect the system to your network. The app guides you through setting connecting the system to your network.

Note: If you do not have a smartphone or tablet, you can use a computer for setup. See page 24.

To add a system to an existing SoundTouch™ account

If you have already set up SoundTouch™ for another system, you do not need to download the SoundTouch™ app again.

1. On your smartphone or tablet, select the SoundTouch™ icon  to launch the app.
2. Select **EXPLORE > SETTINGS > Systems > ADD SYSTEM** to add another system.

Download and install the SoundTouch™ app

After you connect the system to the pedestal and to power, download and install the app:

On your smartphone or tablet, download the **SoundTouch™ controller app**.



Bose SoundTouch™ controller app

- iOS users: download from the App Store
- Android™ users: download from the Google Play™ store

Connect the system to your Wi-Fi network

After you install the app, add the system to your network:

1. On your smartphone or tablet, select  to launch the app. The app guides you through connecting the system to your Wi-Fi network.
2. Follow the instructions in the app to complete setup, including creating a SoundTouch™ account, adding a music library and music services.

Setting the clock

1. Press and hold either **Time –** or **Time +** for about one second.

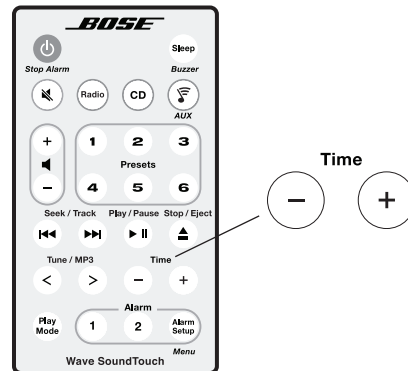

Initially, **HOLD TO SET** appears on the display and then quickly changes to **- CLOCK SET -** as the button is depressed.



2. Release the selected **Time** button.
3. Press **Time –** to adjust the displayed time backward or press **Time +** to adjust the displayed time forward until it matches the current time. You can also press and hold for rapid adjustment.
4. Wait five seconds for the system to exit the clock setup mode.

Note: To change the clock display from 12-hour (AM/PM) time to 24-hour time, see “The setup menu” on page 20.

Note: If the Wave® SoundTouch™ music system loses power due to a power outage or if you unplug the system, all system settings are permanently retained. However, the clock time is temporarily stored in backup memory for up to 48 hours.

Remote control

Use the remote control to operate your Wave® SoundTouch™ music system. Aim the remote at the display and press the buttons. The remote normally works within 20 feet of the display.

Note: Press-and-hold operations require holding the button down for about one second.

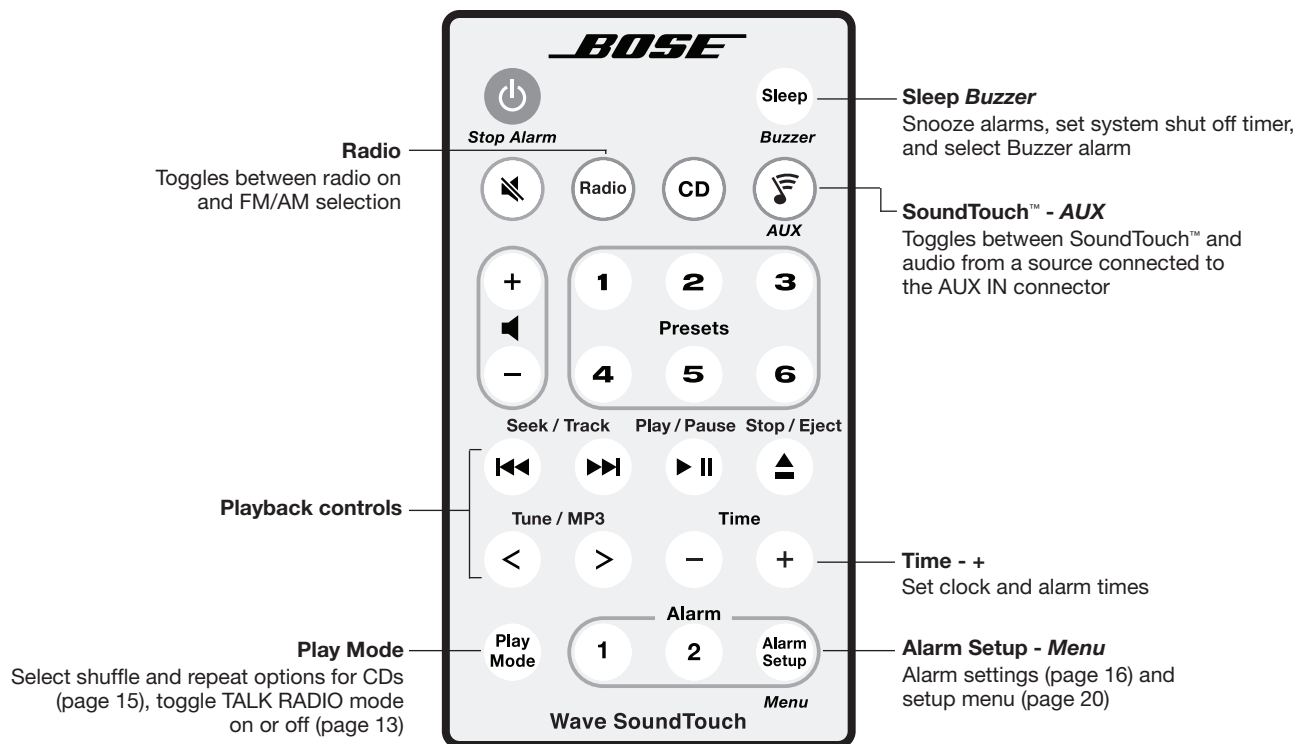

Using the System

Touch pad

Your Wave® SoundTouch™ music system has a touch-sensitive control under the top, front, center area of the top panel.

Momentarily placing your hand on the touch pad can turn your Wave® SoundTouch™ music system on or off, snooze a sounding alarm, and reset it for the next day (page 15).

Note: Pressing , , or  turns on the Wave® SoundTouch™ music system to the selected source.

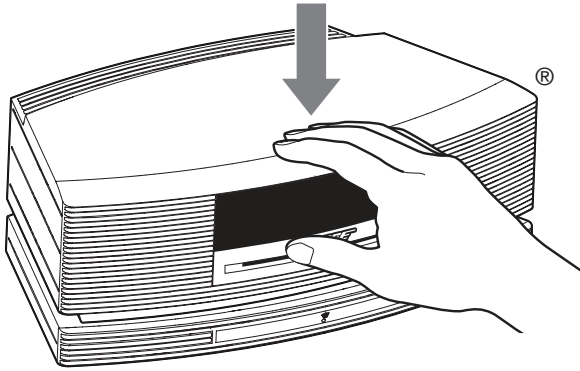

Reading the display

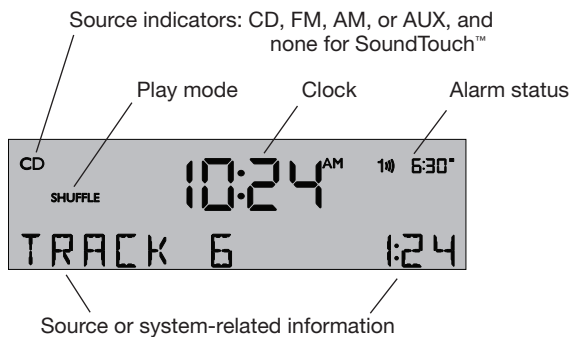

Turning the system on or off

- Press  on the remote control

or

- Touch the touch pad.

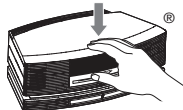

The last source you were listening to is active.

Alternatively:

Press any source button to activate that source.



Note: Selecting **AUX** does not turn on a device connected to AUX IN (such as your TV). Be sure to turn the device on first.



Standby mode

After 24 hours of no button presses, the system switches to standby (off). If the 18-minute system standby timer (page 20) is enabled, the system automatically switches to standby if no audio is played and no buttons are pressed for 18 minutes.

If the system is connected to your network when switching to standby, the connection is maintained while in standby.

Controlling the volume





Press and hold  or  to adjust the volume level.

VOLUME - 0 (silent) to **99** (loud) appears on the display to indicate the level.



Press to mute the system.

Press again, or press  to unmute.

While muted, you can press  to lower the volume before unmuting the system, except when listening to an AirPlay audio stream. Pressing  while listening to AirPlay unmutes the system and then lowers the volume.

Note: When the Wave® SoundTouch™ music system is off, the volume can only be adjusted between 10 and 75.

Setting the Sleep timer



Press **Sleep** to set the Wave® SoundTouch™ music system to shut off automatically after a selected period of time.

- After pressing **Sleep**, **SLEEP - 30 MIN** (or your last setting) appears on the display and the sleep timer begins counting down. If the system is off, press **Sleep** to turn it on and immediately set the sleep time. The last source selected starts playing as the sleep timer counts down.
- While the **SLEEP** setting is displayed, press **Sleep** again to set the sleep timer to 10-90 minutes (in 10-minute increments) or OFF.

Note: If more than 10 seconds elapses between button presses, the Wave® SoundTouch™ music system automatically exits the sleep timer setup mode.

- To review the remaining sleep time, press **Sleep**.
- To cancel the sleep timer, press **On/Off**.

Using the SoundTouch™ app

The SoundTouch™ app is a software application that enables you to set up and control SoundTouch™ from your smartphone, tablet, or computer. Using the app, your smart device acts as a rich remote for the SoundTouch™ source.

The app enables you to manage your SoundTouch™ settings, add music services, explore local and global Internet radio stations, set and change Presets, stream music to the system, view what is playing, plus much more.

After you set up the system on your network using the SoundTouch™ app, you are ready to explore streaming music and personalize your Presets.

Getting help

If you need more information on using the system, use Help Tips or In app help.

Help Tips

After setup is complete helpful tips appear on the screen, based on the task you are trying to complete. These tips instruct you how to use the system, including how to personalize your Presets.

To activate the tips

If you have deactivated tips, follow these instructions to re-activate tips.

1. Launch the SoundTouch™ app and click **EXPLORE > SETTINGS > Help Tips**.
2. Slide the SHOW TIPS slider to ON.

In app help

For information about using SoundTouch™:

1. Click **EXPLORE > HELP** in the app.
2. Browse through the help topics.

Controlling the system from another smartphone, tablet, or computer

Once you set up the SoundTouch™ system on your home Wi-Fi® network, you can control the system from any smartphone, tablet, or computer on the same network.

1. Connect the device to the same network as your system.
2. On the device, download and install the SoundTouch™ app:
 - If you are using a smartphone or tablet, see page 8.
 - If you are using a computer, see page 24.

Personalizing your Presets

How Presets work

You can personalize six Presets to your favorite streaming music services; Internet radio stations; and playlists, artists, albums or songs from your music library. You can access your music at any time with a simple touch of a button on the remote control.

Tip: Access your Presets using the SoundTouch™ app on your smartphone, tablet, or computer.

What you need to know

- You can set Presets from the app and the Wave® SoundTouch™ system remote control.
- If the Preset source is your iTunes or Windows Media Player music library, ensure the computer storing your music library is on and connected to the same network as the Wave® SoundTouch™ system.
- You cannot set Presets from an AirPlay stream or audio device connected to AUX.

Playing a Preset

Once you personalize your Presets using the app, press  on the remote.



SOUNDTOUCH appears on the display until content being streamed through the SoundTouch™ pedestal is available.



Note: When you turn on the system for the first time and select SoundTouch™, content is not available for several seconds. After that, it is much faster.

When content is available, the system plays the last SoundTouch™ item selected unless you press a **Preset** button on the remote.



To skip forward or back through tracks, press (or press and hold) **Seek/Track** forward  or backward .



Note: Some Internet music services do not support skip commands.

Setting a Preset

1. Stream music to the system using the app.
2. While the music is playing, press and hold a Preset on the remote (about 2 seconds). The system emits a tone when the Preset is set.



Note: For more information on using the SoundTouch™ app, refer to the Help system in the app.

Playing an AirPlay stream from an AirPlay compatible device

After connecting the Wave® SoundTouch™ music system to your Wi-Fi® network, it is ready to stream audio from an AirPlay device on the same Wi-Fi network.

1. Start a music app on your AirPlay device.
 2. On the device, tap or click  and select the SoundTouch™ system.
- Tip:** Adjust the volume on the device to 75 percent of maximum to ensure optimal volume control from the system.

3. Start playing music from the music app.
- AIRPLAY** appears on the display followed by information on content playing.

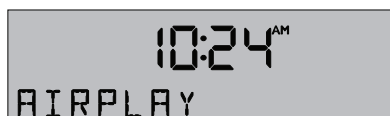

Listening to FM or AM radio

-  Press **Radio** to turn it on to the station last selected.
- Press **Radio** as necessary to select FM or AM radio.

When you select FM radio, Radio Data System (RDS) information for the current station appears. This is controlled by the RADIO TEXT setting in the setup menu. To disable RDS and view only the station frequency, change the RADIO TEXT setting to OFF. See “The setup menu” on page 20.







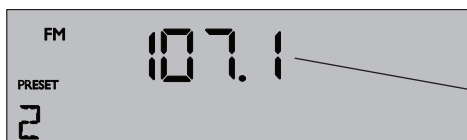





Tuning to an FM/AM station

When you press **Radio**, **Seek/Track**, or **Tune/MP3** to tune to a radio station, the frequency appears in the center of the display while you are tuning.



Station frequency while tuning

- Seek / Track**
 -  Press **Seek/Track**  to find a lower-frequency station with a strong signal.
 -  Press **Seek/Track**  to find a higher-frequency station with a strong signal.
- Tune / MP3**
 -  Press **Tune/MP3**  to manually tune to a lower frequency.
 -  Press **Tune/MP3**  to manually tune to a higher frequency.
 - Press and hold **Tune/MP3**  to rapidly lower the frequency.
 - Press and hold **Tune/MP3**  to rapidly increase the frequency.

Note: If AM reception is weak, rotate your Wave® SoundTouch™ music system clockwise or counterclockwise to improve AM reception. If FM reception is weak, make sure the power cord is straightened as much as possible. To improve FM reception, you can install an external FM antenna. See “Connecting Other Equipment” on page 18.

Storing FM/AM radio station Presets

You can store up to six FM and six AM radio stations for quick recall using the **Presets** buttons. Storing a Preset replaces any station previously stored to that Preset number.



1. Tune to the station you want to save as a Preset.
2. Press and hold a Preset button until you hear a double tone and the Preset number and station frequency appear on the display.
3. Press a Preset button quickly tune to a previously stored FM or AM station.

TALK RADIO mode

Talk radio broadcasts can be greatly affected by either the microphone selection or the boosting of low frequencies by some radio stations. They do so in an attempt to improve speech when heard through conventional radios. In high-quality audio products, this results in sound that is unnatural or bass heavy. By selecting the TALK RADIO mode, your Wave® SoundTouch™ music system automatically adjusts to compensate for artificially boosted low frequencies.

-  When the radio is playing, press **Play Mode** twice to turn the TALK RADIO mode on (**TALK RADIO- ON**) or off (**TALK RADIO- OFF**).

Note: The TALK RADIO setting is automatically cancelled when you tune to another station, switch to another source, or turn your Wave® SoundTouch™ music system off.

Improving FM reception

Unwind and straighten the power cord to ensure the best FM radio reception. The power cord is used as an antenna.

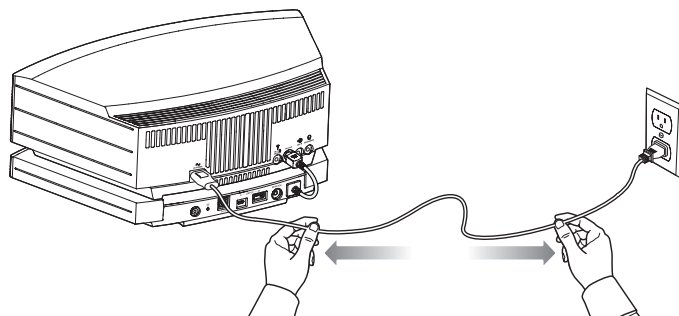

Listening to Other Sources

Playing audio CDs

Insert the disc, label side up, into the CD slot below the display. The disc player pulls the disc in and begins playing.

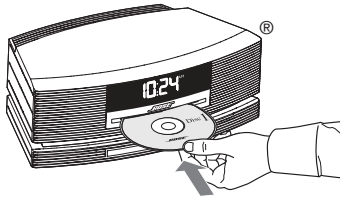

Press **CD** if the CD source is not selected.

When an audio CD is playing, CD source information appears:

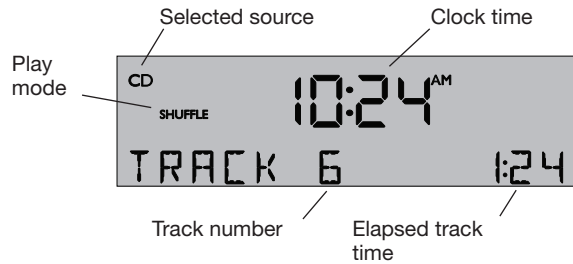

Play / Pause



- Press **Play/Pause** to pause a playing CD. The elapsed time flashes while paused. Press **Play/Pause** again to resume play.

Seek / Track

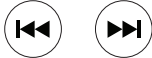

- Press **Seek/Track** **◀◀** to skip to the beginning of the current track; Press **Seek/Track** **◀◀** again to skip to the beginning of the previous track.
- Press **Seek/Track** **▶▶** to skip to the next track.

Tune / MP3



- Press and hold **Tune/MP3** **<** to scan backward quickly through a track; Press **Tune/MP3** **>** to scan forward quickly through a track.

Stop / Eject



- Press **Stop/Eject** to stop a CD. Press **Stop/Eject** again to eject a CD. If a CD is playing, press-and-hold **Stop/Eject** to stop a CD and eject it.

Note: When you play a stopped CD it always resume from the place it was stopped.

Note: If you eject a CD but do not remove it from the CD player slot within 10 seconds, the CD player pulls the CD back into the player and reloads it.

CAUTION: DO NOT INSERT mini CDs or non-circular CDs into the disc player. These discs may not play properly and could interfere with the system's ability to eject them.

Playing MP3 CDs

Your Wave® SoundTouch™ music system can play MP3 music files recorded on CD-R and CD-RW discs.

You can easily navigate through your music files using the **Tune/MP3** and **Seek/Track** remote control buttons.

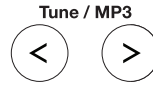

- Press **Tune/MP3** **<** to skip to the previous folder.
- Press **Tune/MP3** **>** to skip to the next folder.



- Press **Seek/Track** **◀◀** to skip to the beginning of the current track.
- Press **Seek/Track** **◀◀** again to skip to the beginning of the previous track.
- Press **Seek/Track** **▶▶** to skip to the next track.

When navigating an MP3 CD, folder number and track number are displayed:

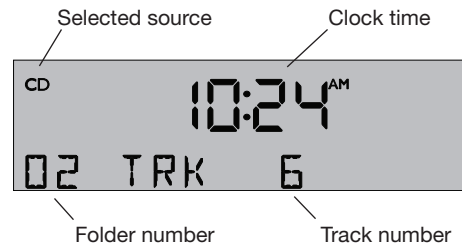

Note: The Root level appears as folder number 00.

Once the track begins playing, artist name, song title, and elapsed track time appears on display:

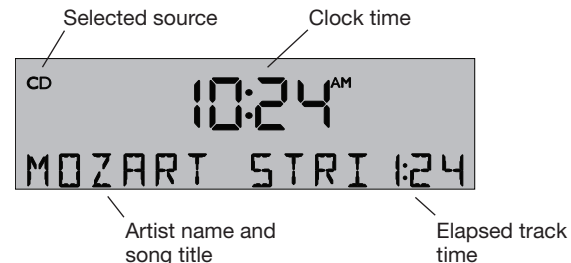

Note: The Wave® SoundTouch™ music system displays artist name and song title information when available on music file CDs.

Note: The audio quality of MP3 CDs is dependent on factors such as the encoded bit rate, the sampling rate, and the type of encoder used. The Wave® SoundTouch™ music system supports MP3 CDs encoded at bit rates of 64kbps or higher, and sampling rates of 32kHz or higher. It is recommended that a bit rate of at least 128kbps and a sampling rate of 44.1kHz or better be used.

Note: Playback quality of recorded CD-R and CD-RW discs is dependent on the CD recording process and software used to record the disc. An improperly recorded audio CD may cause the system to exhibit unexpected behavior.

CD Play Modes

 While a CD is playing, you can change the way it is played. Press **Play Mode** repeatedly until the play mode you want appears:

Mode	CD	MP3	Description
NORMAL PLAY	✓	✓	Plays tracks once in sequential order.
SHUFFLE DISC	✓	✓	Plays all tracks once in random order.
SHUFFLE RPT	✓		Repeats all tracks in a random order that changes each time the disc is repeated.
REPEAT DISC	✓	✓	Repeats the disc from the beginning after the last track is played.
REPEAT TRACK	✓	✓	Repeats the selected track continuously.
SHUFFLE FLDR		✓	Plays all tracks in the selected folder in random order (MP3 only).
SHUF RPT FDR		✓	
SHUFF RPT CD		✓	Repeats all tracks on a disc in a random order that changes each time the disc is repeated.
REPEAT FOLDR		✓	Repeats all tracks in a folder in order (MP3 only).

Note: The play mode returns to NORMAL PLAY whenever a CD is inserted.

Alarm buttons and indicators

The Wave® SoundTouch™ music system has two independent alarms, **Alarm 1** and **Alarm 2**.

Each alarm can be set for:

- Time
- Wake-up source: buzzer, radio, or CD
- Volume

Using the Alarm buttons

Using the Alarm buttons on the bottom of the remote you can setup and operate each alarm:

Press to turn Alarm 1 on or off.

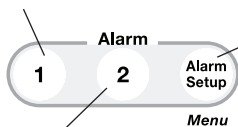

1. Press to activate the Alarm Setup mode and view Alarm 1 settings.
2. Press again to view Alarm 2 settings.
3. Press again to exit the Alarm Setup mode.

Press to turn Alarm 2 on or off.

Alarm status indicators

The upper right-hand corner of the display shows the alarm status indicators if the alarm is set.

Example with Alarm 1 and 2 set:

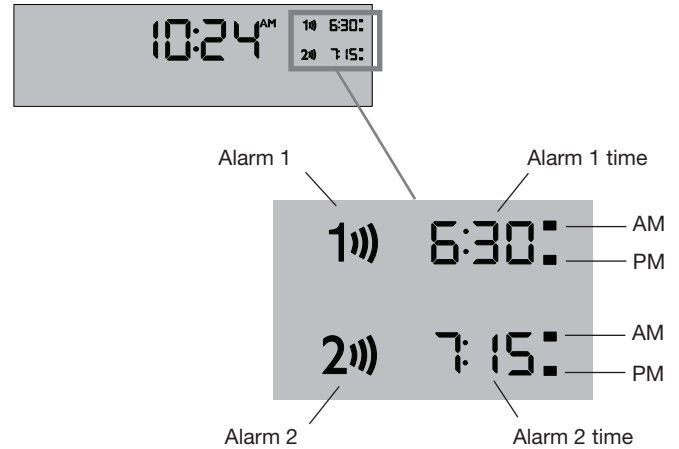

Setting the alarms

You can choose the settings for each alarm by activating the Alarm Setup mode and displaying the settings for the alarm you want to change.

1.  Press **Alarm Setup**.

The alarm number and time start flashing (A) and after a moment, the current Alarm 1 settings are displayed (B).

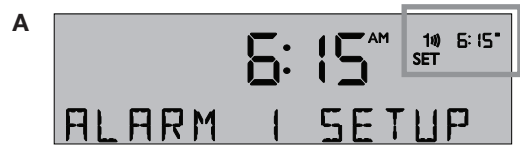

2.  Using the **Time** buttons, set the alarm time.

3. Select your wake-up source:

- BUZZER  is the factory alarm setting.



Buzzer

- Press  to choose a radio station.

- Press  to choose a track.

Note: You cannot select AUX or SoundTouch™ as the wake-up source.

Setting and Using the Alarms

4.  Press **Volume** up or down to set the volume level of the selected wake-up source.
5. Press  to enter the Alarm 2 setup mode.
Repeat Steps 2-4 to set up Alarm 2.
6. Press  again to exit the Alarm Setup mode.

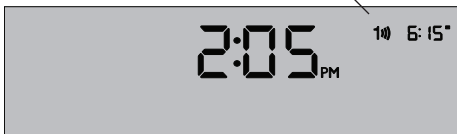

The alarm you set is turned on and the alarm time appears on the display:

Alarm number and time



Using the alarms



Turning an alarm on or off

Press  or  to turn the selected alarm on or off.

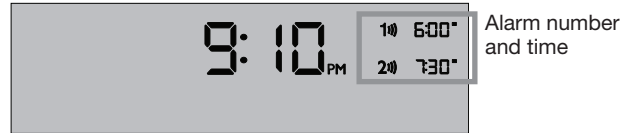
When an alarm is turned on, the alarm number and time appear in the upper right corner of the display.

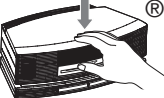

Snoozing an alarm

Touch the touch pad,  or press .

SNOOZE appears for the duration of the selected snooze time and then the alarm sounds again.



The snooze time is set at the factory to 10 minutes. To change the snooze time to 20, 30, 40, 50, or 60 minutes, see "The setup menu" on page 20.

To stop and reset a sounding alarm

Press  .
Stop Alarm

To reset a snoozed alarm for the next day

After snoozing the alarm, place your hand on the touch pad again and hold it there for at least 2 seconds, or press .

Stop Alarm

System connections

The connector panel provides connections for external equipment.

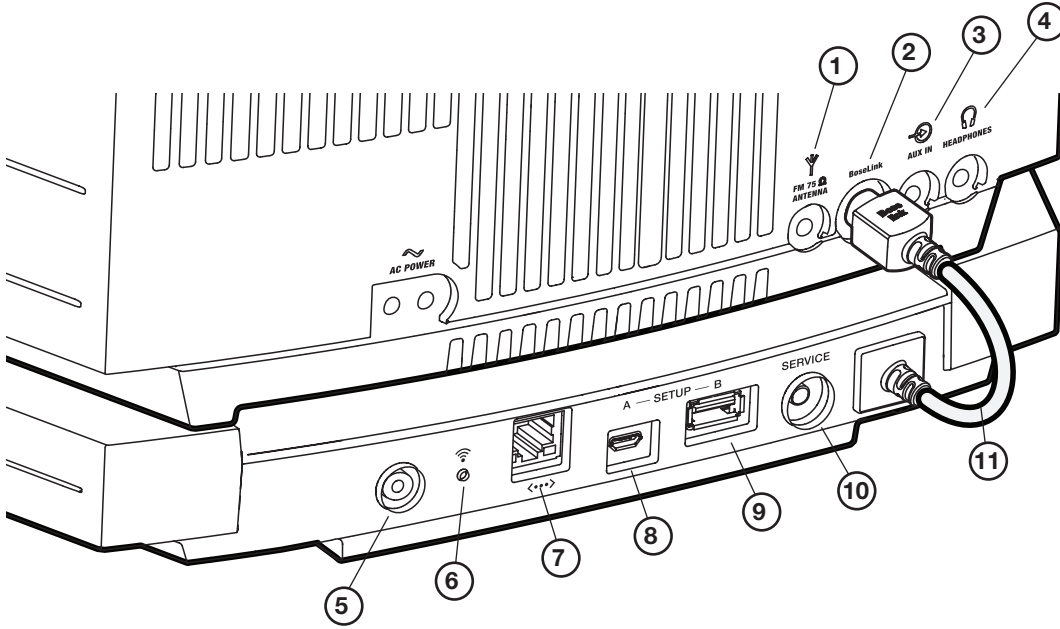

- ① **FM 75Ω ANTENNA**
3.5 mm FM antenna connector (page 19).
- ② **Bose link**
Input connector for the SoundTouch™ pedestal.
- ③ **AUX IN**
3.5 mm stereo input connector for external sources (page 18).
- ④ **HEADPHONES**
A 3.5 mm stereo headphone connector (page 18).
- ⑤ **Control button**
Disables the Wi-Fi® capability (page 21), initiates setup mode, or restarts the SoundTouch™ pedestal (page 21).
- ⑥ **Wi-Fi® indicator:**
 - **Blinking white** – Connecting to Wi-Fi network
 - **Solid white (dim)** – System off and connected to Wi-Fi network
 - **Solid white (bright)** – System on and connected to Wi-Fi network
 - **Blinking amber** – Disconnected from Wi-Fi network
 - **Solid amber** – System is in setup mode
 - **Off** – Wi-Fi networking disabled or system is connected to Ethernet
- ⑦ **Ethernet connector**
Used for a wired network connection.
- ⑧ **SETUP A***
USB Micro-B connector for network setup using a computer.
- ⑨ **SETUP B***
USB Standard A connector reserved for future use.
- ⑩ **SERVICE**
Used for special service functions. Not for customer use.
- ⑪ **SoundTouch™ pedestal Bose link cable**
Plugs into the Bose link connector. It provides power and control signals to the SoundTouch™ pedestal.

* The USB connectors are not designed to charge smartphones, tablets, or similar devices.

Connecting Other Equipment

Using the AUX IN connector

When using a TV, DVD player, computer, video game or other audio source, you can enhance your listening experience by playing the audio device through your Wave® SoundTouch™ music system.

Connecting an audio device to your Wave® SoundTouch™ music system requires one of the following cables:



Male-to-male 3.5 mm stereo cable





Dual RCA male to 3.5 mm male stereo cable

To obtain the correct cable, contact Bose® customer service or visit a local electronics store. Refer to the quick start guide in the carton for contact information.

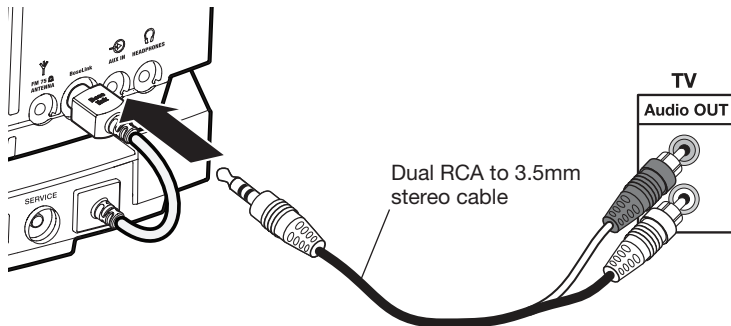

To connect an audio device to the system

1. Connect one end of the stereo cable to the output of the audio device.



2. Connect the other end of the cable to the **AUX IN** connector on the Wave® SoundTouch™ music system's connector panel.
3. Press  on the remote control.
The last source you were listening to is active.
4. Press  once or twice to select the AUX input.
The **AUX** source indicator appears.

Note: If an audio device is plugged into **AUX IN**, pressing  toggles between SoundTouch™ and the audio device.

5. Press and hold  + or  - to adjust the volume.

Note: If the volume level of your Wave® SoundTouch™ music system cannot be adjusted high enough, increase the volume level of the connected audio device.

Using headphones

For private listening, plug the headphones into the headphone connector on the connector panel of the Wave® SoundTouch™ music system.

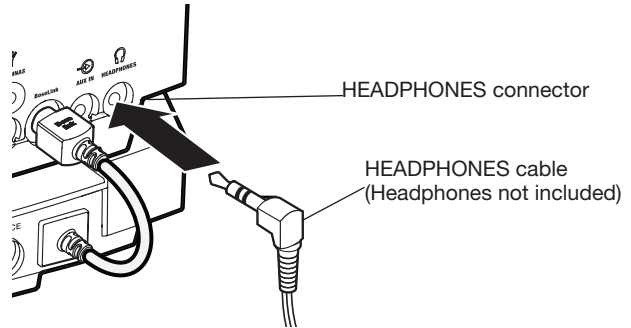



CAUTION: Long-term exposure to loud music may cause hearing damage. It is best to avoid extreme volume when using headphones, especially for extended periods.

Note: The system speakers are muted when you plug in your headphones and unmuted when you disconnect the headphones. Because headphone volume levels may vary from speaker volume levels, lower the volume of the Wave® SoundTouch™ music system before connecting or disconnecting headphones.

Note: If an alarm sounds while using headphones, it sounds through the system speakers.

To change the headphones volume

Press and hold  + or  - to adjust the volume of your headphones.

Using an external antenna

The Wave® SoundTouch™ music system's power cord is used as an antenna for FM radio. If, after adjusting the position of the power cord, you still experience poor reception, you may need to install an external antenna. An external dipole antenna can be ordered through Bose Customer Service. Refer to the quick start guide in the carton for contact information.

1. Insert the 3.5 mm plug of the FM antenna into the **FM ANTENNA** connector.
2. Extend the ends of the antenna as far from the unit and other external equipment as possible to establish optimum reception.

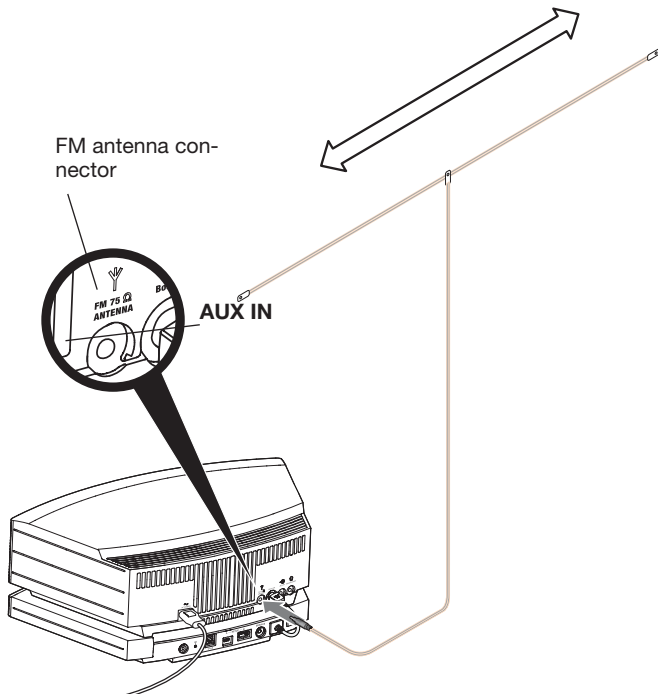

Note: Many FM radio stations transmit a vertically polarized signal as well as, or instead of, a horizontally polarized signal. If the horizontal antenna orientation does not provide good reception, try hanging the antenna in a vertical orientation.





Personalizing Your Wave® SoundTouch™ Music System

The setup menu

Use the setup menu to customize the operation of the Wave® SoundTouch™ music system.

System Setting	Menu Item	Factory Setting	Choices	Description
Snooze Duration	SNOOZE-	10 MIN	10 MIN, 20 MIN, 30 MIN, 40 MIN, 50 MIN, 60 MIN	Determines the snooze time duration.
Radio Data System (RDS) Information	RADIO TEXT-	ON	ON, OFF	Enables (ON) or disables (OFF) the system to display RDS information.
Continuous Play	CONT PLAY-	NO	NO, AUX, FM, AM	Determines which source plays after a CD ends.
Clock Time Format	TIME-	12 HOUR	12-HOUR, 24-HOUR	Sets the clock display for 12-hour (AM/PM) or 24-hour time.
Display High Brightness Level	BRIGHT HI-	10	8-15	Sets the display brightness level when the unit detects high ambient light conditions.
Display Low Brightness Level	BRIGHT LO-	4	1-8	Sets the display brightness level when the unit detects low ambient light conditions.
Room Code (Not applicable when using the SoundTouch™ pedestal.)	ROOM-	B _ _ _ -	B _ _ _ -, C _ _ _ -, D _ _ _ -, E _ _ _ -, F _ _ _ -, G _ _ _ -, H _ _ _ -, I _ _ _ -, J _ _ _ -, K _ _ _ -, L _ _ _ -, M _ _ _ -, N _ _ _ -, O _ _ _ -	Sets the room code for the Wave® SoundTouch™ music system when it is connected to a Bose link network. The dashes following the room letter indicate how the microswitches should be set on a Lifestyle® remote control.
Capacitive touch control	TOUCH PAD-	ON	ON, OFF	Enables (ON) or disables (OFF) the touch pad.
18-minute system standby timer	AUTO OFF-	YES	YES, NO	Enables (YES) or disables (NO) the 18-minute system standby timer. Refer to “Turning the system on or off” on page 10.
Factory reset	RESET ALL-	NO	NO, YES	Restores the Wave® SoundTouch™ music system to factory settings.

To change a system setting

1. Press and hold  until **-SETUP MENU-** appears.
2. Press  until the item you want to change appears.
3. Press   to change the value or selection.
4. Press  to exit the setup menu or wait 10 seconds for the setup menu to close.

Disabling Wi-Fi® capability

The SoundTouch™ pedestal has built-in Wi-Fi capability that enables wireless connectivity and AirPlay.

1. Press and hold the pedestal's Control button (8-10 seconds).
2. When the Wi-Fi indicator turns off, release the Control button.

Re-enabling Wi-Fi® capability

Turn on the Wave SoundTouch™ music system using the remote control.

Restarting the SoundTouch™ pedestal

On the back of the SoundTouch™ pedestal, press and hold the Control button for more than 10 seconds and then release it. After several seconds the pedestal should turn on again and reconnect with your network.

Note: Restarting does not affect your SoundTouch™ Presets or your saved network credentials.

Resetting the SoundTouch™ pedestal



Reset the SoundTouch™ pedestal to clear all SoundTouch™ source information and network credentials from the system and return it to original factory settings.

Note: This reset function erases your SoundTouch™ Presets and saved network credentials. It does not affect your FM and AM Presets.

1. Ensure that the SoundTouch™ pedestal's cable is inserted into the Bose link connector.
2. Disconnect the system from power.
3. Press and hold the Control button on the back of the SoundTouch™ pedestal.
4. While pressing and holding the Control button, reconnect power.
5. Hold the Control button for five seconds and then release it. The system restarts.
6. Launch the SoundTouch™ app and add the system to your network (see page 8).

Care and Maintenance

Troubleshooting

Problem	What to do
System does not function	<ul style="list-style-type: none">• Plug the power cord fully into a live AC (mains) power outlet.• Unplug the power cord from the AC wall outlet for 10 seconds and then reconnect it; this resets the system.• Tap the touch pad on the top of the system to turn it on (page 10).
Cannot complete network setup	<ul style="list-style-type: none">• Plug the SoundTouch™ pedestal into the Bose link connector and power on the system.• Stop other audio or video streaming on your network.• Close the SoundTouch™ app and restart the setup process (page 8).• Place system within range of the router.• Enable Wi-Fi® on the device (mobile or computer) you are using for setup.• Connect the device and SoundTouch™ system to the same Wi-Fi network.• Select correct network name and enter password.• If network name does not appear or is hidden, select Manually Connect to Another Network on the CONNECT TO HOME WI-FI NETWORK screen.• Close other open applications.• If using a computer for setup, check firewall settings to ensure that the SoundTouch™ app and SoundTouch™ Music Server are allowed programs.• Test your Internet connection by loading SoundTouch.com• Restart your mobile device, or computer, and router.• Reboot your system (refer to Help system in the app).• Uninstall the app, reset the system, and restart setup.• Visit SoundTouch.com, contact Bose Support (refer to the quick start guide in the carton for contact information, or refer to the Help system in the app).
AirPlay	<ul style="list-style-type: none">• Connect system and AirPlay device to the same network.• Select the system in the device's AirPlay menu.• Ensure AirPlay device is playing; increase its volume.• Move AirPlay device away from possible interference and closer to the wireless router or access point.• Restart your mobile device, or computer, and router. <p>Note: Proximity of the AirPlay device to the system is not important, only to the wireless router or access point.</p>
No sound	<ul style="list-style-type: none">• Increase the volume.• Press Mute .• Eject and reload the CD.• Press  to listen to SoundTouch™. <p>Make sure the SoundTouch™ pedestal is connected to your Wi-Fi network.</p> <ul style="list-style-type: none">• Press  to listen to an external source connected to the AUX IN connector.• Turn on the external source and increase the volume.• Disconnect headphones from the system (connecting headphones mutes the speakers).
Poor sound quality	<ul style="list-style-type: none">• If listening to an AM or FM source, try turning the Talk Radio mode on or off (page 13).• If listening to an external AUX source, use a stereo cable and make sure it is fully inserted.
Remote control is inconsistent or does not work	<ul style="list-style-type: none">• Operate the remote control closer to the system.• Check that the remote control battery is installed with positive (+) polarity facing up.• Replace the remote control battery.• Check for interference from fluorescent room lighting, sunlight, or dust or dirt on lens.• Place the system in a different location.
AM reception is weak	<ul style="list-style-type: none">• Turn the system slightly one way and then the other to change the direction of the internal AM antenna.• Move the system farther from a TV, refrigerator, halogen lamps, dimmer switches, or other electronic equipment that generates electrical noise.• If neither suggestion works, you may be in an area of weak AM signal coverage.
FM reception is weak	<ul style="list-style-type: none">• Extend the power cord as much as possible. The power cord acts as an FM antenna (page 13).• See "Connecting Other Equipment" on page 18.
CD does not play	<ul style="list-style-type: none">• Select the CD source or press CD. The CD icon appears on the display.• Load the CD label-side up.• Check that the disc surface is clean. If not, try cleaning it.• Check that an audio CD was loaded, not a DVD.• Try another disc.

Replacing the remote control battery

1. Place the remote face down on a flat surface.
2. Using your finger, push the tab lock to the side as shown and hold. Slide the battery compartment open.

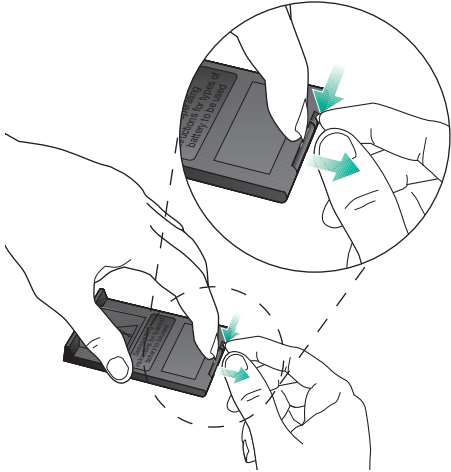

3. Remove the old battery and install the new one with the plus (+) symbol facing up.

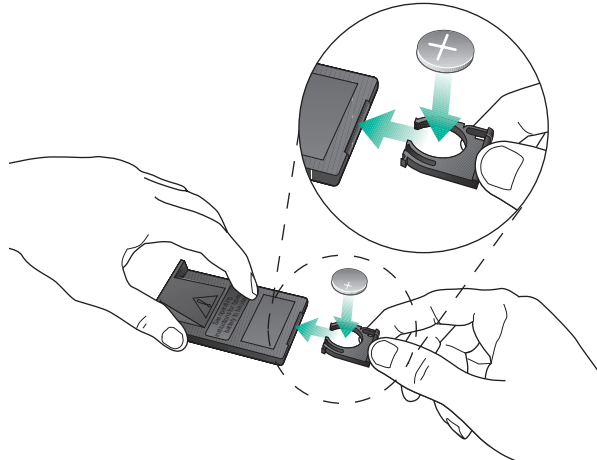

4. Gently slide the battery compartment closed. It locks automatically.

WARNING: Keep new and used batteries away from children. Do not ingest battery, chemical burn hazard. The remote control supplied with this product contains a coin/button cell battery. If the coin/button cell battery is swallowed it can cause severe internal burns in just two hours and can lead to death. If the battery compartment does not close securely, stop using the product and keep it away from children. If you think the battery may have been swallowed or placed inside any part of the body, seek immediate medical attention. The coin/button cell battery may explode or cause a fire or chemical burn if incorrectly replaced or mishandled. Do not recharge, disassemble, heat above 212°F (100°C), or incinerate. Replace only with an agency approved (ex. UL) CR2032 or DL2032 3-volt lithium battery. Dispose of used batteries promptly.

Cleaning

Use only a soft dry cloth to clean your Wave® SoundTouch™ music system. If necessary, you may use a soft-bristled attachment to gently vacuum the front of the enclosure. Do not use any liquid cleaning solutions, solvents, chemicals, alcohol, ammonia, or abrasives.

Do not allow liquids to spill into any openings in the enclosure. If liquids get into the unit, unplug the product immediately. Call Bose Customer Support as soon as possible to arrange for service. See the contact information sheet included in the shipping carton.

Customer service

If you lose your remote, additional remotes are available from Bose Customer Service. For additional help in solving problems, contact Bose Customer Service. See the contact information sheet included in the shipping carton.

Limited warranty

Your Bose® Wave® SoundTouch™ music system is covered by a limited warranty. Details of the limited warranty are provided in the warranty information on the quick start guide. Please complete registration online. Failure to do so will not affect your limited warranty rights.

The warranty information provided with this product does not apply in Australia and New Zealand. See our website at www.bose.com.au/warranty or www.bose.co.nz/warranty for details of the Australia and New Zealand warranty.

Technical information

AC power rating

220V-240V ~ 50/60Hz 60W max.

Dimensions

14.6" W x 8.6" D x 5.6" H (36.8 cm x 21.9 cm x 14.3 cm)

Weight

9.9 lb (4.5 kg)

Appendix: Setting up Using a Computer

Important setup information

- You can set up your system using a computer rather than a smartphone or tablet.
- You need the provided USB cable.
- Use a computer that is on your Wi-Fi® network.
- Do not connect the USB cable until the app instructs you to connect the cable.
- Use the computer where your music library is stored.

Using a desktop computer for setup

If you are using a desktop computer, move your system near the computer to set it up. You must temporarily connect the USB cable from the computer to the system. Then, you can move the system to its permanent location.

Setting up the system using a computer

1. Place the system on the pedestal (see page 7).
2. On your computer, open a browser and go to **SoundTouch.com/app**
Tip: Use the computer where your music library is stored.
3. Download and run the SoundTouch™ app.
4. Connect the system to your home network (see page 8).
The app guides you through setup.



730920-0010

BOSE[®]
Better sound through research[®]

©2014 Bose Corporation, The Mountain,
Framingham, MA 01701-9168 USA
AM730920 Rev. 03