

***BOSE***® ControlSpace® Engineered Sound Processor

**Safety Instructions  
&  
Install Guide**



# Important Safety Instructions

## Caution marks on the product

These CAUTION marks are located on the back of the product.



The lightning flash with arrowhead symbol, within an equilateral triangle, is intended to alert the user to the presence of uninsulated dangerous voltage within the system enclosure that may be of sufficient magnitude to constitute a risk of electric shock.



The exclamation point within an equilateral triangle, as marked on the system, is intended to alert the user to the presence of important operating and maintenance instructions in this owner's guide.

## Important safety instructions

1. **Read these instructions.**
2. **Keep these instructions** – for future reference.
3. **Heed all warnings** – on the product and in the owner's guide.
4. **Follow all instructions.**
5. **Do not use this apparatus near water or moisture.**
6. **Clean only with a dry cloth.**
7. **Do not block any ventilation openings. Install in accordance with the manufacturer's instructions.**

To ensure reliable operation of the product and to protect it from overheating, put the product in a position and location that will not interfere with its proper ventilation.
8. **Do not install near any heat sources, such as radiators, heat registers, stoves, or other apparatus (including amplifiers) that produce heat.**
9. **Do not defeat the safety purpose of the polarized or grounding-type plug. A polarized plug has two blades with one wider than the other. A grounding-type plug has two blades and a third grounding prong. The wider blade or third prong are provided for your safety. If the provided plug does not fit in your outlet, consult an electrician for replacement of the obsolete outlet.**
10. **Protect the power cord from being walked on or pinched, particularly at plugs, convenience receptacles, and the point where they exit from the apparatus.**
11. **Only use attachments/accessories specified by the manufacturer.**
12. **Use only with the cart, stand, tripod, bracket, or table specified by the manufacturer or sold with the apparatus. When a cart is used, use caution when moving the cart/apparatus combination to avoid injury from tip-over.**
13. **Unplug this apparatus during lightning storms or when unused for long periods of time to prevent damage to this product.**
14. **Refer all servicing to qualified service personnel. Servicing is required when the apparatus has been damaged in any way such as power-supply cord or plug is damaged; liquid has been spilled or objects have fallen into the apparatus; the apparatus has been exposed to rain or moisture, does not operate normally, or has been dropped.** Do not attempt to service this product yourself. Opening or removing covers



may expose you to dangerous voltages or other hazards. Please call Bose to be referred to an authorized service center near you.

15. **To prevent risk of fire or electric shock, avoid overloading wall outlets, extension cords, or integral convenience receptacles.**
16. **Do not let objects or liquids enter the product** – as they may touch dangerous voltage points or short-out parts that could result in a fire or electric shock.
17. **See product enclosure for safety related markings.**
18. **No naked flame sources, such as lighted candles, should be placed on the apparatus.**
19. **The mains plug is used to disconnect the device and it shall remain readily operable. To completely disconnect the power input, the mains plug of the apparatus shall be disconnected from the mains.**
20. **The POWER indicator LED will illuminate green when the product has mains power. If power is applied and the LED is not illuminated, or if the LED is red, please send the unit for service.**



**WARNING:** To reduce the risk of fire or electric shock, do not expose the product to rain or moisture.



**WARNING:** The apparatus shall not be exposed to dripping or splashing, and objects filled with liquids, such as vases, shall not be placed on the apparatus with any electronic products, use care not to spill liquids into any part of the system. Liquids can cause a failure and/or a fire hazard.

## Information about products that generate electrical noise

If applicable, this equipment has been tested and found to comply with the limits for a Class B digital device, pursuant to Part 15 of the FCC rules. These limits are designed to provide reasonable protection against harmful interference in a residential installation. This equipment generates, uses, and can radiate radio frequency energy and, if not installed and used in accordance with the instructions, may cause harmful interference to radio communications. However, this is no guarantee that interference will not occur in a particular installation. If this equipment does cause harmful interference to radio or television reception, which can be determined by turning the equipment off and on, you are encouraged to try to correct the interference by one or more of the following measures:

- Reorient or relocate the receiving antenna.
- Increase the separation between the equipment and receiver.
- Connect the equipment to an outlet on a different circuit than the one to which the receiver is connected.
- Consult the dealer or an experienced radio/TV technician for help.

This product complies with the Canadian ICES-003 Class B specifications.



This product conforms to the EMC directive 89/336/EEC and to the Low Voltage Directive 73/23/EEC. The complete Declaration of Conformity can be found on [www.bose.com](http://www.bose.com).

## Important Safety Instructions

### Rack mounting considerations

This audio signal processor requires two 1.75" (4.4 cm) rack space units with 12.8" (32.5 cm) inside depth. When mounting, use four screws with washers to prevent marring the front panel. Neoprene rubber washers are a good choice because they grip the screw heads and prevent the screws from backing out due to vibration or during transportation.

**Note:** *If mounting below a product that protrudes past the face of the rack, always leave a one rack space above the processor to allow access to the front door.*

**CAUTION:** *If the unit is rack-mounted and the rack is transported, you must mechanically support the rear of the processor. You can place a shelf across the rear of the processor to support the weight of the chassis.*

### General precautions

**CAUTION:** *Place the unit where it will be protected from heat and allow adequate ventilation. Place the unit away from direct heat sources, such as heating vents and radiators. Make sure the air can circulate freely behind, beside and above the unit.*

*Do not allow the chassis to exceed the maximum operating temperature of 35°C. Be aware of conditions in an enclosed rack that may increase the temperature above room ambient conditions.*

**CAUTION:** *Be sure all the fine strands of the wire are twisted together and contained within the connector. If even one strand is loose and can touch the adjacent terminal, a short circuit may occur.*

The information furnished in this guide does not include all of the details of design, production, or variations of the equipment. Nor does it cover every possible situation which may arise during installation, operation, or maintenance. If you need assistance beyond the scope of this installation guide, please contact our Customer Service department.

## Introduction

The Bose® ControlSpace® Engineered Sound Processor is a flexible, expandable and high-quality digital audio signal processor. The ESP-88 (base model) includes eight inputs (microphone or line-level selectable) and eight line level outputs. Four available audio slots allow up to 64 channels of audio.

Multiple choices of user controllers are available to provide end-users with simple, easy-to-use control of their ControlSpace system.

The Bose ControlSpace® Designer software is used to design systems and configure the and user control. The software runs on a PC and communicates to the ESP over Ethernet.

## Features and functions:

The Bose ControlSpace Engineered Sound Processor offers the following features and functions:

- Expandable and flexible cardframe architecture allows up to 64 channels of audio in a single chassis
- DSP expansion slot allows DSP processing power and delay times to increase fourfold
- Eight general purpose control inputs and eight general purpose control outputs (GPIO)
- GPIO expansion slot allows up to 16 control inputs and 16 control outputs
- All audio input and output channels feature tri-color level LEDs
- Design, control and configuration via PC-based software and Ethernet connection
- Large set of signal processing modules including: Bose loudspeaker EQs, crossovers, automatic microphone mixer, graphic and parametric EQs, routers, delays, matrix mix signal generators, meters, compressors/Lim duckers, automatic gain controls, gate and source selectors

The ControlSpace Engineered Sound Processor is available in two versions:

**ESP-00** — no audio cards installed so the unit can be custom configured to meet the needs of the application.

**ESP-88** — an 8x8 configuration is pre-loaded with 8 standard dynamic range inputs, and 8 standard dynamic range outputs.

## Quick start

- Install the ControlSpace Designer software included with the ESP (always check [www.pro.bose.com](http://www.pro.bose.com) for latest version.)
- Use the supplied Ethernet crossover cable to connect your PC's Ethernet port to the ESP's LAN port.
- The PC's Link LED should illuminate and the Ethernet LED on the front of the ESP should be green.
- Press the "Go on-line" button; the Designer software should find the ESP and try to connect to it.
- Once connected, the background of the Project View will change to light blue. Continue to configure the ESP as desired.

# Front Panel Indicators and Features

## Front Panel

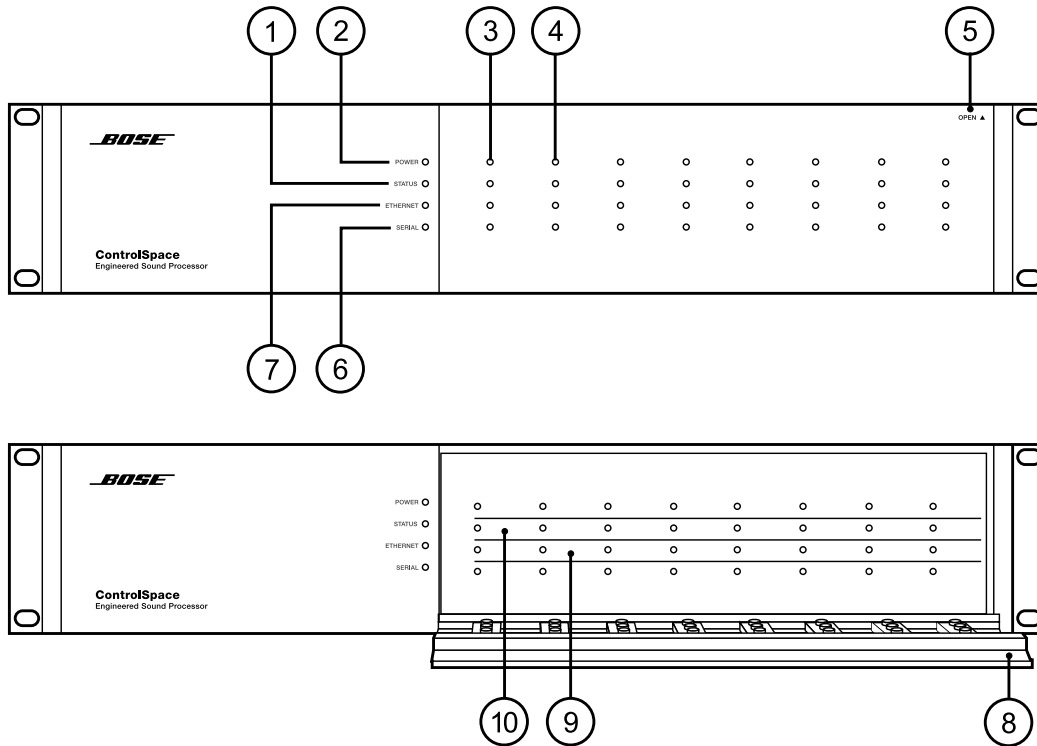

### 1. Status indicator

- Green = Netlist loaded, operating
- Yellow = DSP resource shortage (delay or cycles)
- Red = Error in netlist
- Off = No netlist loaded

### 2. Power indicator

- Green = Power on
- Red = Fatal error

### 3. Audio input indicators (4 per audio card slot)

- Green = Input signal > -36dBu/-60dBFS
- Yellow = Input signal > = +4dBu/-20dBFS
- Red = Clipping, input signal > = +18.0dBu/-6.0dBFS

### 4. Audio output indicators (4 per audio card slot)

- Green = Output signal > -36dBu/-60dBFS
- Yellow = Output signal > = +4dBu/-20dBFS
- Red = Clipping, output signal > = +18.0dBu/-6.0dBFS

### 5. Front door

Shown closed, pull to open

### 6. Serial indicator

- Red = RS232: Rx/Tx
- Yellow = RS485: CC-16 controller command received
- Green = RS485: CC-16 controller command transmitted

### 7. Ethernet indicator

- Green = Link
- Yellow = Tx activity
- Red = Rx activity

### 8. Front door

Shown open

### 9. Audio output label area

Apply labels in this area to indicate the names of the output signals (e.g. "Center Fill")

### 10. Audio input label area

Apply labels in this area to indicate the names of the output signals (e.g. "Podium Mic")

# Rear Panel Controls and Connections

## Rear Panel

(ESP-88 shown ESP-00 does not include I/O cards and must be configured separately.)

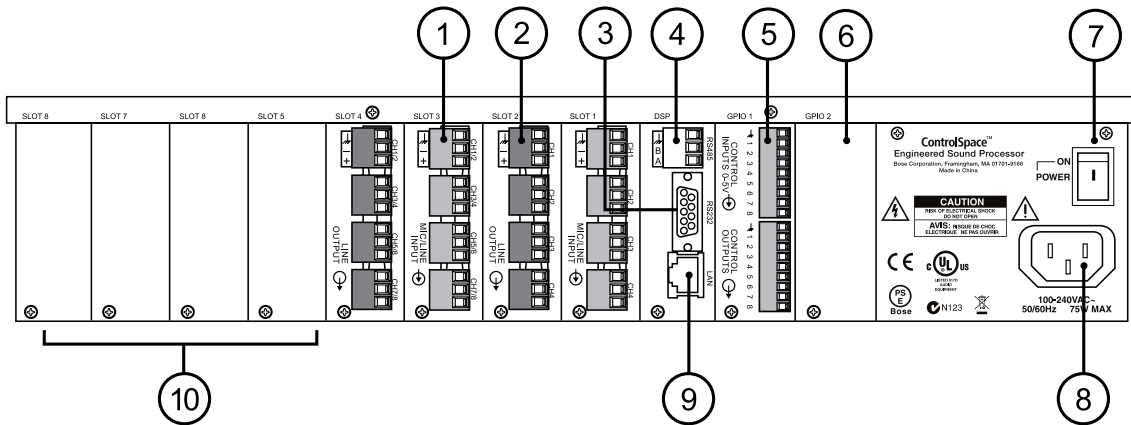

**1. Mic/line inputs** (*ESP-88 only*)

Four balanced mic/line inputs (audio input connectors are green) in slots 1 and 3. These are inputs S1-1 through S1-4, and S3-1 through S3-4 in the ControlSpace™ Designer software.

**2. Line outputs** (*ESP-88 only*)

Four balanced line outputs (audio output connectors are orange) in slots 2 and 4. These are outputs S2-1 through S2-4 and S4-1 through S4-4 in the Designer software.

**3. RS-232C connector**

DB-9 male (DTE)

**4. RS-485 connector**

Connect ControlSpace CC-16 controllers.

**5. GPIO card**

Eight general purpose control inputs  
Eight general purpose control outputs

**6. GPIO slot 2**

For optional 2nd GPIO card

**7. Power switch**

ON/OFF AC power

**8. AC cord inlet**

Connect the AC cord appropriate for your area.

**9. Ethernet LAN connector**

Connect to your PC with enclosed cross-over cable. Or, connect directly to a hub or router with a straight-through cable.

**10. Audio slots 5 - 8**

For optional audio cards

### RS-232C Serial Port

The ESP features a serial port that can be used to send to other equipment. The serial port is a DB9 male. The pin-out is shown in this illustration.

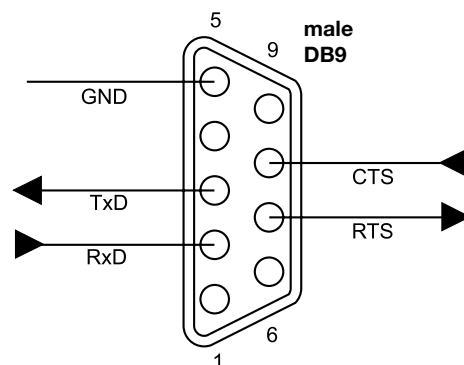

## Modularity and Expansion

### Flexible architecture

The ESP employs a flexible, modular architecture. The flexible architecture provides two levels of DSP performance: up to 32 general purpose control inputs and outputs, and up to 64 audio channels.

Remove the eight screws from the cover of the ESP and slide off the top to access the expansion card slots.

### ESP Inside View

(ESP-00 shown with optional DSP daughter card)



**CAUTION:** Installation should only be performed by trained service personnel.



**CAUTION:** Make no modification to the system or accessories. Unauthorized alterations may compromise safety, regulatory compliance and system performance.



**CAUTION:** ESD sensitive device. Handle with care.

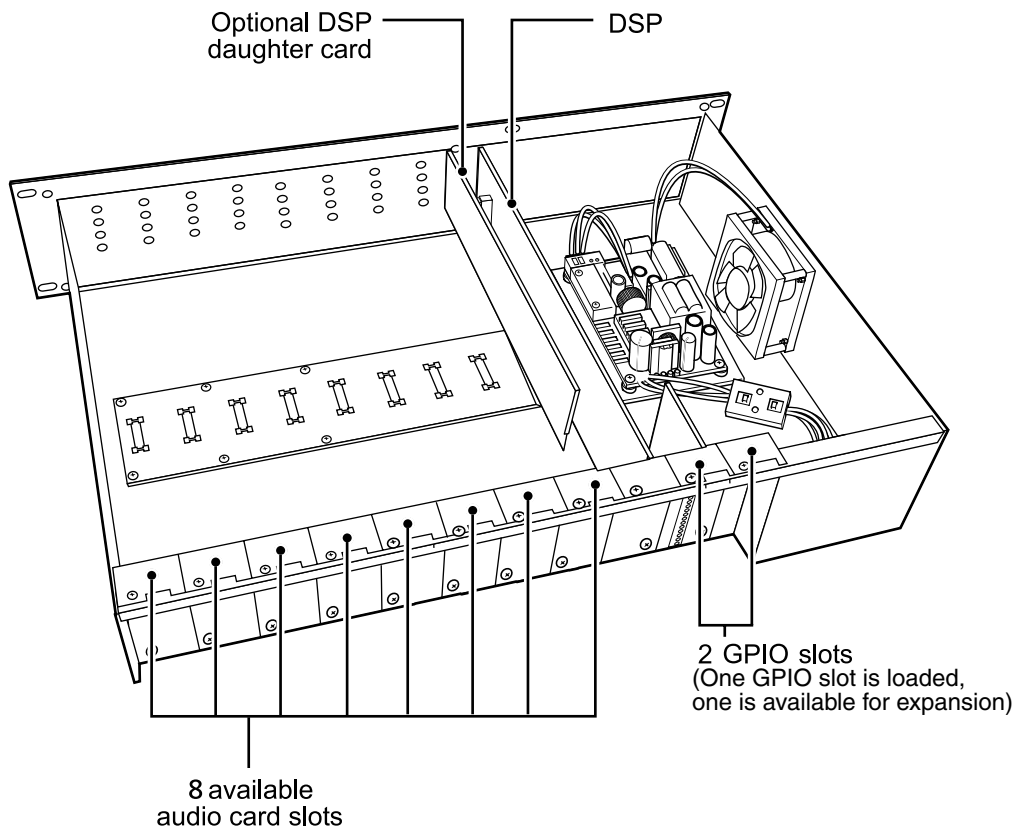

### Expansion cards

Three types of optional cards are available: DSP expansion; GPIO; and Audio.

#### DSP expansion card PC041769

Daughter card for main DSP card. Increases performance by 300%. One card can be added to an ESP.

#### GPIO card PC041768

Fits in the available GPIO slot. Eight control inputs and eight control outputs. One GPIO card can be added to an ESP.

Audio Cards:

#### 4x4 mic/line card PC041915

Occupies two audio slots. Four microphone or line level inputs (software selectable), and four line level outputs.

#### EDR line level output card PC041763

Occupies one audio slot. Four highest-quality, line level outputs.

#### EDR line level input card PC041764

Occupies one audio slot. Four highest-quality, line level inputs.

#### AES3 output card PC041766

Occupies one audio slot. Eight AES3 outputs (two per output connector).

#### AES3 input card PC041765

Occupies one audio slot. Eight AES3 inputs (two per input connector).

#### Four-channel mic/line input card PC041917

Occupies one audio slot and four microphone or line-level inputs (software-selectable).

#### Four-channel SDR output card PC041916

Occupies one audio slot. Four line-level outputs.

#### Surround Sound Decoder input card PC302210

Occupies one audio slot. One optical audio input and one coaxial audio input

### Maximum expansion card configuration

The ESP-00 has eight available audio expansion slots and two available GPIO slots.

4 ch input/output	4x28	8x24	12x20	16x16	20x12	24x8	28x4
4 ch input/4x4 I/O	20x12	24x12	20x8	24x8	24x4	28x8	32x4
EDR in/EDR out	4x28	8x24	12x20	16x16	20x12	24x8	28x4
AES-3 in/AES-3 out	8x56	16x48	24x40	36x36	40x24	48x16	56x8
AES-3 in/EDR out	8x28	16x24	24x20	36x16	40x12	48x8	56x4
EDR in/AES-3-out	4x56	8x48	12x40	16x32	20x24	24x16	28x8

Other configurations can be created by mixing SDR and EDR cards which are not shown here.



## Audio connections

A microphone or line level audio source can be connected to the Mic/Line inputs using one of the following wiring methods.

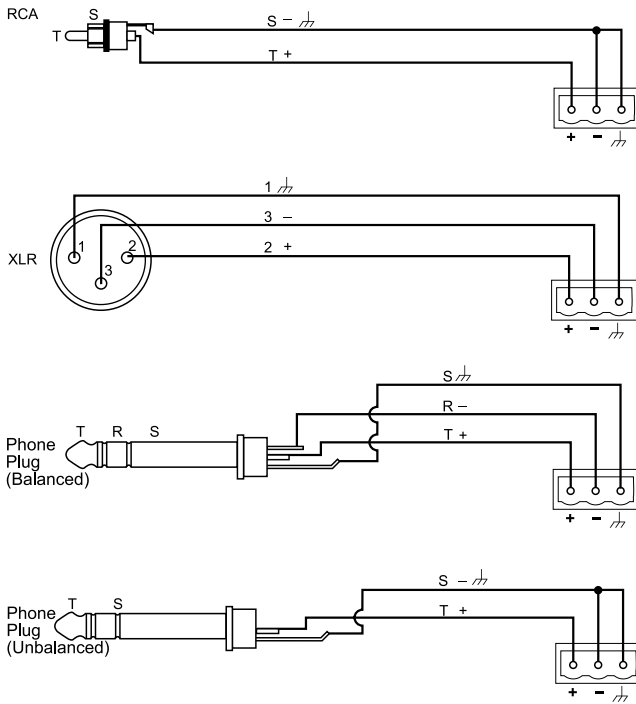

## General Purpose Inputs/Outputs (GPIO) cards

Two GPIO card slots provide up to 16 control inputs and 16 control outputs. The GPIO inputs are used to accept hardware-based control signals from switches, relays or potentiometers.

### Inputs

Switches and potentiometers can be connected to the control inputs to control various functions in the system. For example, simple ON/OFF switches can be connected and then programmed to invoke presets, select scenes, or invoke a snapshot of a control. Likewise, 10k potentiometers (linear) can be connected to control gains in the system.

When used for gain control, the control input expects to see 0 ohms for full gain and 10k ohms for "OFF" or muted. This is to prevent unterminated or loose connections from inadvertently causing full-gain audio, since the port features an internal pull-up resistor. Therefore, wire the potentiometer such that the fully rotated clockwise position (full gain from the user's perspective) is 0 ohms and the fully counterclockwise position is 10k ohms.

Inputs include a 5k ohm pull-up resistor allowing SPST switches to be wired from input to ground. Potentiometers can be wired in series from the control input to ground.

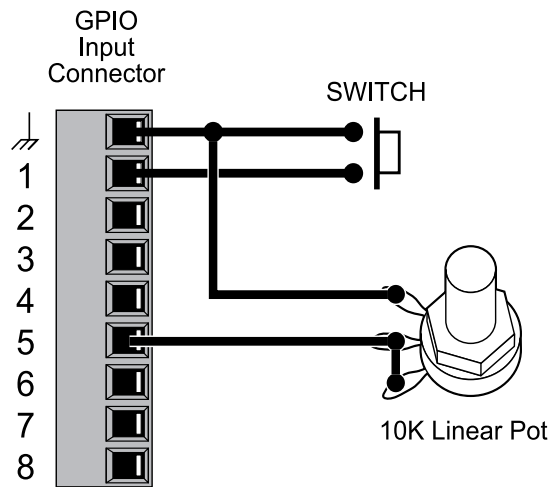

### Outputs

LEDs and relays can be connected to general purpose outputs to indicate state changes in the system (e.g. preset or scene changes).

A maximum of 10mA (sink; 0.5mA source) per output is available and therefore care must be taken when selecting components. Select LEDs that are "High Efficiency" and require only 10mA forward current. For relays, only those rated with an LED forward current of 10mA or less, such as some solid state relays, can be connected directly. Most mechanical relays require more than 10mA drive current and are not suitable for direct connection. Alternatively, an external power supply and transistors can be used to drive higher current LEDs or relays.

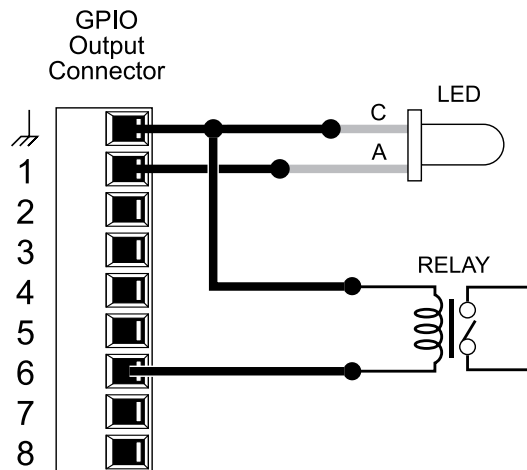

## Troubleshooting

No Power	<ul style="list-style-type: none"> <li>• Turn power on, plug in power cord.</li> </ul>
Power is on but no sound	<ul style="list-style-type: none"> <li>• Verify that there is an input signal from the source. The audio input indicator should be green (or yellow).</li> <li>• Verify that there is an output signal. The audio output signal indicator should be green (or yellow).</li> <li>• If there is an input signal (indicator green) and no output signal (indicators off), the ESP may be muted, output levels may be down, or the unit may be completely unprogrammed. Run ControlSpace® Designer software and connect to the ESP and verify. Signals should be passing from inputs to outputs.</li> </ul>
Power is on but sound is low	<ul style="list-style-type: none"> <li>• Verify that the audio input indicator is green. If it is off, increase the source output or use the Designer software to increase the input gain.</li> <li>• If the audio input indicator is green and the audio output signal indicator is green, verify there is enough gain in the amplifier.</li> </ul>
Sound is distorted	<ul style="list-style-type: none"> <li>• Verify that the audio input signal indicators are not solid red or flashing red. If they are, reduce the source output level or use the Designer software to reduce the input gain.</li> <li>• Verify that the audio output signal indicators are not solid red or flashing red. If they are, and the input indicators are green, use the Designer software to reduce the output gain or any intermediary gain in the signal path.</li> <li>• If the input source signal is clean when it enters the ESP system, and the input and output indicators are green, verify that the loudspeakers are not being overdriven and are not damaged.</li> </ul>
Unnatural sound	<ul style="list-style-type: none"> <li>• Verify that the correct EQ and/or crossover is used in the signal path.</li> </ul>
Status LED is off	<ul style="list-style-type: none"> <li>• Power is off or netlist is not loaded. Use ControlSpace Designer software to load a netlist/configuration</li> </ul>
Ethernet LED is off	<ul style="list-style-type: none"> <li>• Verify that the ESP LAN port is connected to a PC with a crossover cable.</li> <li>• Verify that the Ethernet LAN connection on the PC is enabled. If it is not enabled, the Link LED on the PC will probably be off.</li> <li>• If connected to a hub or switch, check that device's Link LED.</li> <li>• If connected to a hub or switch, verify the ESP and PC are connected with straight-through cables to the hub or switch.</li> </ul>
Ethernet LED is on but cannot communicate with ESP	<ul style="list-style-type: none"> <li>• Verify that the LAN settings on the Ethernet device you are using on the PC are communicate with the ESP set correctly: <ul style="list-style-type: none"> <li>- Internet Protocol (TCP/IP) is installed as a protocol on this device</li> <li>- IP address is set to 192.168.0.88</li> <li>- Subnet mask is set to 255.255.255.0</li> </ul> </li> <li>• Verify that there is not another LAN connection enabled.</li> <li>• Verify that there is not another ESP connected with the same address. If unsure, disconnect one, scan for the remaining unit, and change its address. Repeat with the second unit.</li> </ul>

## Technical Specifications

### Signal processing

<b>Type</b>	32-bit floating-point digital signal processor(s)
<b>Clock speed</b>	200MHz
<b>Maximum calculation</b>	1600 MIPS/1200MFLOPS (6400MIPS/4800MFLOPS with DSP option card)
<b>Delay memory</b>	16MByte/72s(Maximum) (64MByte/288s(Maximum) with DSP option card)
<b>Audio latency</b>	610us (analog in to analog out) (860us with DSP option card)
<b>Sampling rate</b>	48kHz

### Communication ports

<b>LAN</b>	10Base-T (RJ-45)
<b>RS-232C</b>	D-Sub 9 pin, male; DTE
<b>RS-485</b>	Phoenix/Euroblock 2-piece, 3-pin

### Indicators

<b>Status</b>	Power/Status/Ethernet/Serial (RS232C + RS485)
<b>Audio</b>	Signal (Present/Normal/Clip) for each audio input and output

### Expansion slots

<b>Audio I/O</b>	8 Slots (4 in ESP-88)
<b>Control I/O</b>	1 Slot Max 16 inputs/16 outputs
<b>DSP</b>	1 Slot

### Audio channels

<b>Analog</b>	32 max (all slots full)
<b>Digital (AES3)</b>	64 (all slots full)

### Mechanical

<b>Dimensions</b>	18.9" W x 3.5" H x 12.6" D (482 mm x 88 mm x 320 mm)
<b>Weight</b>	11.5 lb (5.3kg)

### Electrical

<b>Mains voltage</b>	85-264VAC 50/60Hz with PFC
<b>Power consumption</b>	< 35VA
<b>Maximum power consumption</b>	<70VA (at <35°C ambient)

### Environmental

<b>Operating temperature</b>	<50°C at less than 35VA / <40°C at less than 70VA
<b>Humidity</b>	80% relative humidity (without condensation)

# Technical Specifications

## Dimensions

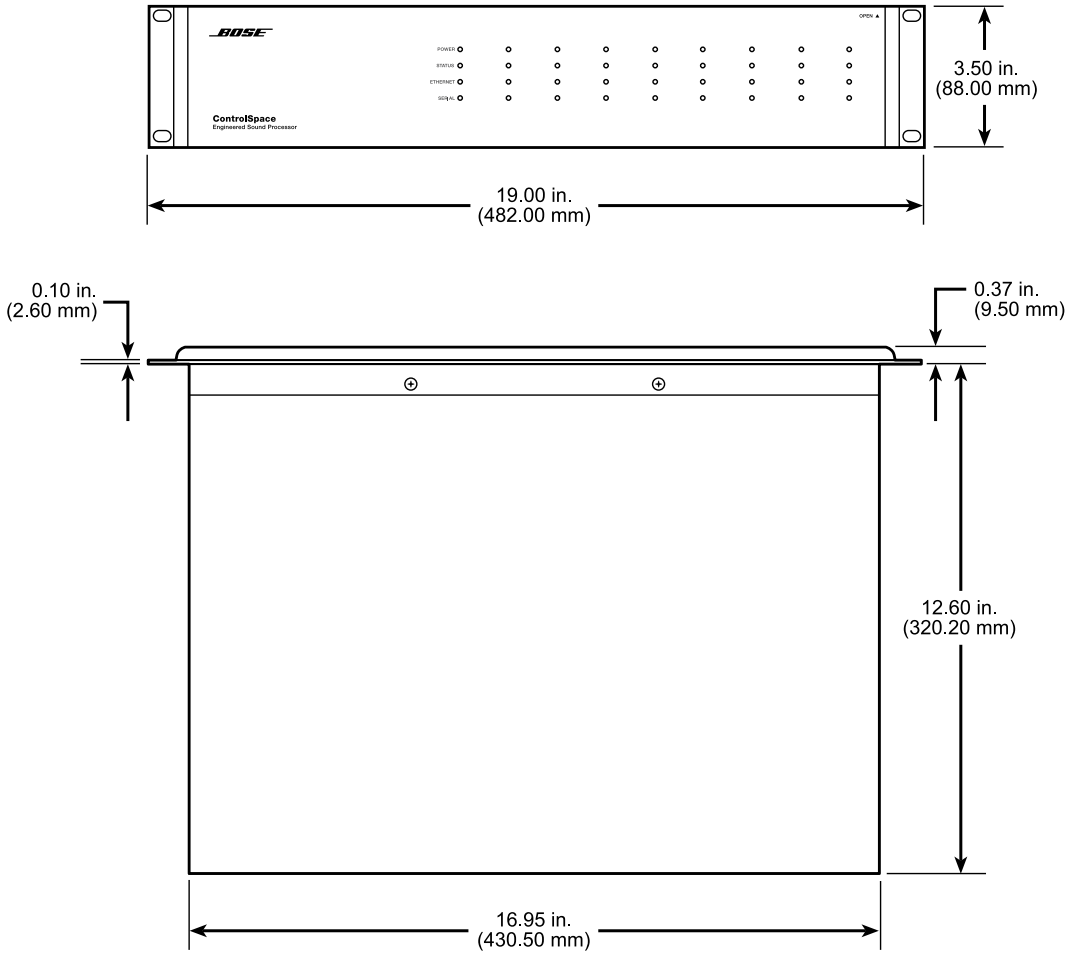

**Bose® Product Sales Conditions**  
**Limited Warranty Policy and Conditions of Sale**  
**Bose Corporation**  
**The Mountain, Framingham, MA 01701**

**What is covered:**

All parts defective in material and workmanship. This limited warranty for the Bose® ControlSpace® ESP Engineered Sound Processor covers the functionality of the system for its normal, intended use as specified in the Owner's Guide and does not cover a malfunction that has resulted from improper or unreasonable use or maintenance, accident, excess moisture, improper packing, lightning, power surges, or unauthorized tampering, alteration or modification while not under the control of Bose. Bose systems are not designed to be used in every environment, so please review your Owner's Guide. WHERE PERMITTED, THE PROVISIONS OF THIS LIMITED WARRANTY ARE IN LIEU OF ANY OTHER WRITTEN WARRANTY, WHETHER EXPRESS OR IMPLIED, WRITTEN OR ORAL, INCLUDING ANY WARRANTY OF MERCHANTABILITY OR FITNESS FOR A PARTICULAR PURPOSE.

**For how long:**

In countries where the duration of the warranty is not determined by statute, the Bose Limited Warranty lasts five years from the purchase date. For countries where minimum warranty terms are determined by statute, the warranty term is the longer of the statutory period or the term listed above.

**What we will do:**

We will repair or replace any defective parts within a reasonable period of time and free of charge.

**How you can obtain warranty service:**

1. You can ship the system to either a Bose Service Agency or to Bose directly with a proof of purchase from an authorized dealer.  
  
Please:
  - A. Properly and carefully pack the product for shipping. If you need a carton for shipping, contact Bose for a new carton.
  - B. Label and ship the product to the appropriate Bose location.
  - C. Please contact Bose to get a return reference number. Place this number prominently on the outside of the carton.
2. You can return the system with proof of purchase from an authorized dealer to a Bose Service Agency or directly to Bose. Proof of purchase is not required where it is excluded by statute.

**Other Rights:**

**EXCLUSIVE REMEDY:**

THIS LIMITED WARRANTY IS FULLY TRANSFERABLE PROVIDED THAT THE CURRENT OWNER FURNISHES THE ORIGINAL PROOF OF PURCHASE FROM AN AUTHORIZED BOSE DEALER. THE MAXIMUM LIABILITY OF BOSE SHALL NOT EXCEED THE ACTUAL PURCHASE PRICE PAID BY YOU FOR THE PRODUCT. IN NO EVENT SHALL BOSE BE LIABLE FOR SPECIAL, INCIDENTAL, CONSEQUENTIAL OR INDIRECT DAMAGES. SOME PLACES DO NOT ALLOW LIMITATIONS ON THE EXCLUSION OR LIMITATION OF RELIEF, SPECIAL, INCIDENTAL, CONSEQUENTIAL OR INDIRECT DAMAGES OF THE LIMITATION OF LIABILITY TO SPECIFIED AMOUNTS, SO THE ABOVE LIMITATIONS OR EXCLUSIONS MAY NOT APPLY TO YOU.

**OTHER CONDITIONS:**

FOR YOUR BENEFIT, WE RECOMMEND THAT YOU RECORD YOUR SERIAL NUMBER(S), FOUND ON THE PRODUCT(S), AND OTHER PURCHASE INFORMATION, AND KEEP IT WITH YOUR PERSONAL RECORDS ALONG WITH PROOF OF PURCHASE. IF NECESSARY, THIS INFORMATION WILL ALLOW US TO BETTER SERVE YOUR NEEDS.

THIS LIMITED WARRANTY GIVES YOU SPECIFIC RIGHTS SUBJECT TO SPECIFIED CONDITIONS. YOU MAY ALSO HAVE OTHER LEGAL RIGHTS WHICH APPLY TO THE PRODUCT YOU HAVE ACQUIRED. THESE LEGAL RIGHTS VARY FROM STATE TO STATE OR COUNTRY TO COUNTRY. SOME PLACES DO NOT ALLOW THE EXCLUSION, RESTRICTION OR MODIFICATION OF CERTAIN IMPLIED RIGHTS OR THEIR EFFECT. IN THOSE SITUATIONS THIS LIMITED WARRANTY WILL ONLY APPLY TO THE EXTENT THAT THE APPLICABLE LAW ALLOWS. OTHER LAWS PROVIDE YOU WITH A STATUTORY CLAIM AGAINST THE SELLER.

The laws of your state or country may provide you with legal claims against the seller or manufacturer of this product. The Limited Warranty does not affect those rights.

**Remedies:**

The provisions of this limited warranty are in lieu of any other warranties or conditions, except those provided by law. This Limited Warranty does not affect any legal rights provided to you by law and does not preclude any legal remedy you may have under the law.

This Limited Warranty is fully transferable provided that the current owner furnishes the original proof of purchase from an authorized Bose dealer.

This Limited Warranty is void if the label bearing the serial number has been removed or defaced.



***BOSE***<sup>®</sup>  
*Better sound through research*<sup>®</sup>

2010 Bose Corporation, The Mountain,  
Framingham, MA 01701-9168 USA

AM316788 Rev 01